(19)  **Canadian
Intellectual Property
Office**

An Agency of
Industry Canada

**Office de la Propriété
Intellectuelle
du Canada**

Un organisme
d'industrie Canada

(11) **CA 553651** (13) **A**

(40) **04.03.1958**

(12)

(21) Application number: **553651D**

(51) Int. Cl:

(22) Date of filing: ..

(71) Applicant: **PELLARINI LUIGI.
ROSSETTI FABIO.**

(72) Inventor: **PELLARINI LUIGI ().
ROSSETTI FABIO ().**

(54) **TORSION LEVER**

(57) **Abstract:**

(54) **LEVIER A TORSION**

This First Page has been artificially created and is not part of the CIPO Official Publication

The present invention relates to an elastic element for elastic suspensions in general, characterized in that an articulated four faced frame contains a block of material having elastic properties, said block being bound to the four faces of said frame, the cross section (along a plane perpendicular to the articulations of said frame) of said block when in its resting position, having a parallelogram shape, with at least an acute angle, and said element being destined to be stressed so that the opening of said acute angle increases under load.

One preferred form of embodiment of the present invention is diagrammatically shown, merely by way of example, in the attached drawings, wherein:

Figure 1 is a perspective view of the frame containing the block of elastic material,

Figures 2, 3, and 4 show three different positions of said frame when stressed, and

Figure 5 shows the concerned qualitative diagram.

With reference to the drawings, 1 is the four faced frame, the surfaces whereof are articulated in 2, 3, 4 and 5.

6 is a block of rubber or rubber substitute contained in said frame, bound to the inner surfaces of the aforesaid faces, by means of adhesives. When in its resting position, said rubber block 6 has, on a plane perpendicular to the articulations, a cross section having a parallelogram shape with two opposite acute angles, 7, 8.

Figures 2, 3 and 4 show three different positions of the frame 6 when stressed. The elastic element is connected in its hingeing points 2, 3 to the part to be suspended, while the lever 9, of the part receiving the external stresses, is connected on the side 3,4.

The three aforesaid positions are described with reference to Figure 5, showing on abscisse the deformations, and on the ordinates the external loads.

In said Figure 5, the curve 10 is the diagram of the

moments due to the stresses produced in the block by causing the frame to deform the block from its position of rest. The area of the front surface of the frame remains constant while the volume of the block varies when the acute angle passes from 70° to 90° and beyond this value changing its sine when passing from 90° to 110° ;

5 the curve 11 is the diagram of the moments due to shear, and the curve 12 is the resultant of the two afore-cited curves and in flexure is inverted in its central portion, corresponding about to the static load.

10 An elastic element, according to this invention having the characteristic curve 12 has the advantage of avoiding the necessity of braking or damping elements, since the load variations are small for the normal deformation.

15 The load variations are only the ones necessary for bringing again the suspended part to its initial position, by overcoming its inertia.

4

THE EMBODIMENTS OF THE INVENTION IN WHICH AN EXCLUSIVE
PROPERTY OR PRIVILEGE IS CLAIMED ARE DEFINED AS FOLLOWS:

1. Elastic element for resilient suspensions in general, comprising an articulated four sided frame, within the frame a block of material having high elastic properties bonded to the inner surface of the four sides of said frame, said block, when in its resting position having a parallelogram shape in cross section with opposite acute angles, and means cooperating with one of said sides and adapted to stress said block so that the opening of said acute angle increases under load.
2. Element according to claim 1, in which each plane of bonding of the block to the frame passes through the axes of two contiguous articulations.
3. Element according to claim 1 or 2, in which the articulations are arranged outside of the elastic block, so that the intersections of the bond surfaces coincide with the articulation axis.

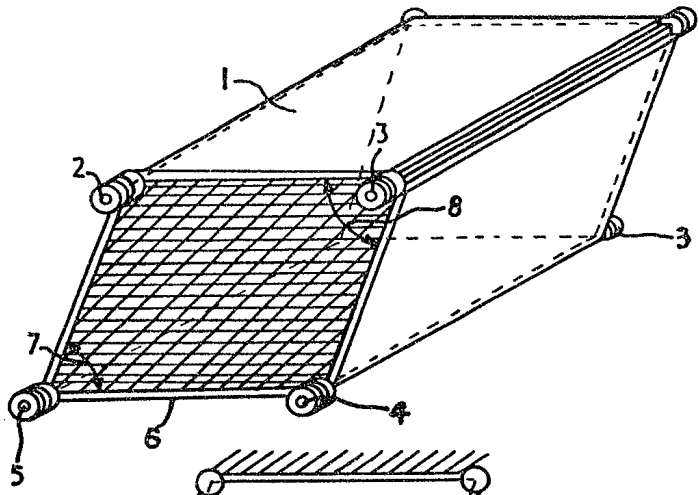

FIG. 1

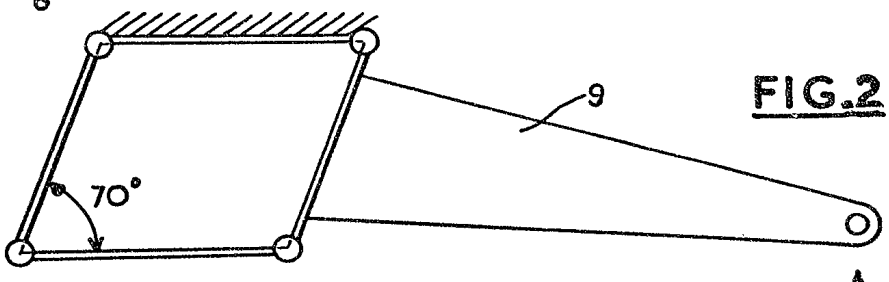

FIG. 2

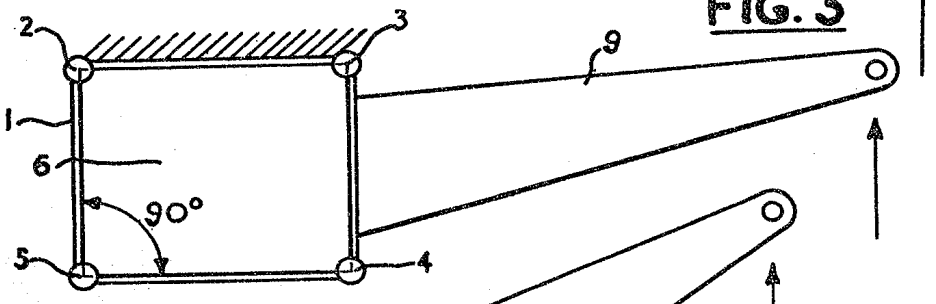

FIG. 3

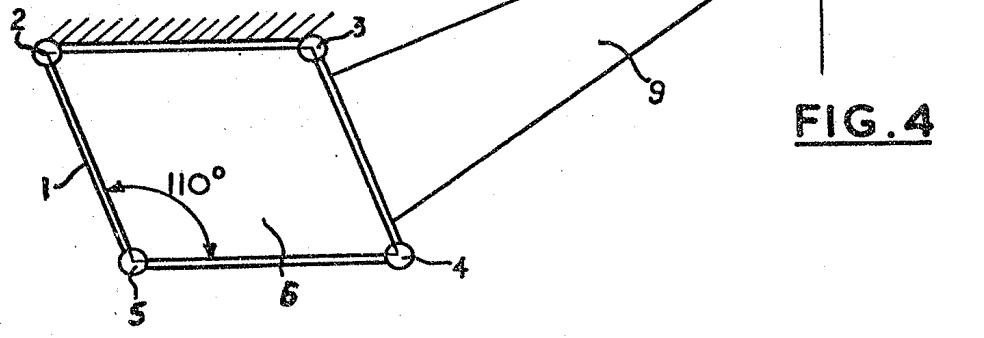

FIG. 4

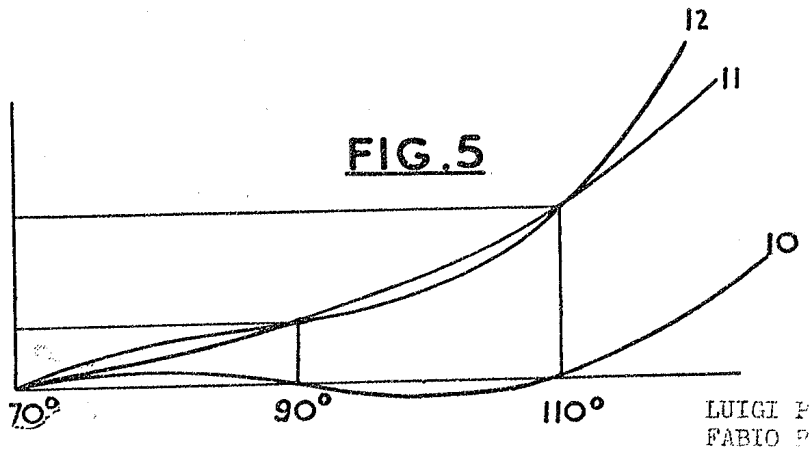

FIG. 5

INVENTORS
 LUIGI PELLAPINI and
 FABIO POSSETTI
 PATENT AGENTS

F. & C.
 & Co