

(19) World Intellectual Property Organization
International Bureau



(43) International Publication Date
8 August 2002 (08.08.2002)

PCT

(10) International Publication Number
WO 02/061015 A1

- (51) International Patent Classification⁷: C10G 1/10, 1/02, C10B 53/00
- (74) Agent: JOSHI, Hiral, Chandrakant; Chandrakant M. Joshi, 501, Vishwananak, Andheri - Kurla Road, Mumbai 400 099, Maharashtra (IN).
- (21) International Application Number: PCT/IN01/00061
- (22) International Filing Date: 29 March 2001 (29.03.2001)
- (25) Filing Language: English
- (26) Publication Language: English
- (30) Priority Data:
102/MUM/2001 29 January 2001 (29.01.2001) IN
103/MUM/2001 29 January 2001 (29.01.2001) IN
- (81) Designated States (*national*): AE, AG, AL, AM, AT, AU, AZ, BA, BB, BG, BR, BY, BZ, CA, CH, CN, CO, CR, CU, CZ, DE, DK, DM, DZ, EE, ES, FI, GB, GD, GE, GH, GM, HR, HU, ID, IL, IN, IS, JP, KE, KG, KP, KR, KZ, LC, LK, LR, LS, LT, LU, LV, MA, MD, MG, MK, MN, MW, MX, MZ, NO, NZ, PL, PT, RO, RU, SD, SE, SG, SI, SK, SL, TJ, TM, TR, TT, TZ, UA, UG, US, UZ, VN, YU, ZA, ZW.
- (84) Designated States (*regional*): ARIPO patent (GH, GM, KE, LS, MW, MZ, SD, SL, SZ, TZ, UG, ZW), Eurasian patent (AM, AZ, BY, KG, KZ, MD, RU, TJ, TM), European patent (AT, BE, CH, CY, DE, DK, ES, FI, FR, GB, GR, IE, IT, LU, MC, NL, PT, SE, TR), OAPI patent (BF, BJ, CF, CG, CI, CM, GA, GN, GW, ML, MR, NE, SN, TD, TG).
- (71) Applicants and
(72) Inventors: ZADGAONKAR, Umesh, Arun [IN/IN]; 9, Buty Layout, Laxmi Nagar, Nagpur 440 022, Maharashtra (IN). ZADGAONKAR, Alka, Umesh [IN/IN]; 9, Buty Layout, Laxmi Nagar, Nagpur 440 022, Maharashtra (IN).
- Published:
— with international search report

[Continued on next page]

(54) Title: A PROCESS AND APPARATUS FOR MANUFACTURE OF LIQUID FUEL FROM WASTE PLASTIC AND REFINERY WASTE

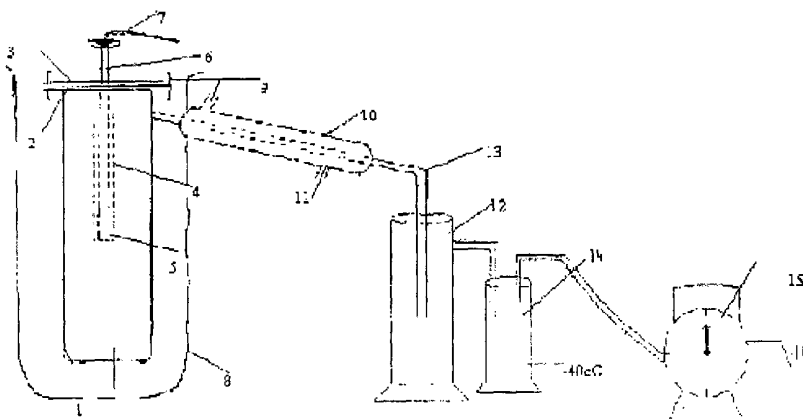

(57) Abstract: An improved apparatus consisting of a cylindrical rectangular a coking vessel (1) heated by electrical heating coils or any other form of energy said vessel is made from stainless steel or mild steel and surrounded by heat reflector and insulator to avoid heat loss and to achieve maximum heating inside locked at the top (2) with temperature sensor which extended upto the center of the vessel; the other end protruding outside is connected to a controlled unit by means of wiring; said lid is provided with high temperature gasket for locking by means of lock and bolt; said coking vessel is provided at its side an outlet vent to correct condensing section/condenser (10) the other end of the condenser is connected to the receiving section; said condenser is provided with outer jacket for circulating cold water or thermic fluid from the bottom (11) as and when required for the conversion of gaseous form of product into liquid state; the said condenser is connected to the receiving assembly/unit (12) by means of suitable conduit (13) in tandem with other receiving unit (14) or gasometer (15) and a outlet vent towards the gas collecting and sealing unit (16) said receiving unit is maintained at a temperature [-]40 °C to room temperature or higher to collect the distillate in batches or continuously.



WO 02/061015 A1



For two-letter codes and other abbreviations, refer to the "Guidance Notes on Codes and Abbreviations" appearing at the beginning of each regular issue of the PCT Gazette.

TITLE OF INVENTION

A Process and Apparatus for Manufacture of Liquid Fuel from Waste Plastic and Refinery Waste.

FIELD OF INVENTION

5 The invention relates to an improved apparatus for manufacturing of Petrol / Kerosene/ diesel/ furnace oil/ lubricating oil fractions, Petroleum gases and coke from any type of waste plastic and refinery waste, refinery residue, coal tar or any type of secondary residue or any type of waste oil.

10 More particularly the invention relates to an improved apparatus wherein higher yield distillate consist of Petrol/ Kerosene / diesel / furnace oil / lubricating oil fractions obtained with monitored & controlled temperature and fully controlled reaction process.

The conventional process of manufacturing these distillates are well known which consist of heating the refinery waste into volatile mass and liquefying into liquid and subsequent fractional distillation wherein the yield was upto 50%. It requires further
15 processing for purification. The apparatus used are furnace, condensing unit & receiver.

By research & development ~~the inventor has found an improved apparatus for~~ manufacturing of Petrol / Kerosene/ diesel/ furnace oil/ lubricating oil fractions, Petroleum gases and coke from any type of waste plastic and refinery waste, refinery residue, coal tar or any type of secondary residue or any type of waste oil to obtain lighter distillate in
20 a full proof manner wherein refinery waste is charged with waste plastic and additives to obtain higher yield of distillate up to 95% with high purity / quality.

The refinery waste hereto mentioned means apart from refinery waste, refinery residue coal tar or any other type of bitumen or any other type of secondary residue or any other type of waste oil and/or a mixture thereof.

25 Waste plastic means polypropylene, low density , polyethylene , high density polyethylene or any other plastic and/or mixture thereof.

The distillate means of combination of petrol/ kerosene / diesel / furnace oil / lubricating oil fraction.

The refinery waste, waste plastic and distillates referred wherever desired hereunder are consists of above definitions.

BACKGROUND OF INVENTION

5 The principle object of this invention is therefore to provide an improved apparatus for the utilisation and conversion of waste plastic into usable product such as petrol / kerosene / diesel / furnace oil / lubricating oil fractions, petroleum gases & coke. All are usable products that too without any waste or hazardous by-product.

10 Still further object of this invention is to provide an improved apparatus for manufacturing of Petrol / Kerosene/ diesel/ furnace oil / lubricant oil fractions, Petroleum gases and coke from any type of waste plastic and refinery waste, refinery residue, coal tar or any type of secondary residue or any type of waste oil to obtain higher yield of distillates at controlled temperature by means of electric sensor.

15 Still further an improved apparatus for manufacturing of Petrol / Kerosene/ diesel/ furnace oil/ lubricating oil fractions, Petroleum gases and coke from any type of waste plastic and refinery waste, refinery residue, coal tar or any type of secondary residue or any type of waste oil to provide an improved apparatus consisting of coking chamber / coking section, condenser / condensing section , receiving unit , receiving section. With an electronic / electrical device to control & monitor the temperature within the coking chamber and other sections to achieve higher yields of distillate with high purity thereby cost effective,
20 safe and userfriendly.

Still further object of this invention is to provide an improved apparatus for manufacturing of Petrol / Kerosene/ diesel/ furnace oil/ lubricating oil fractions, Petroleum gases and coke from any type of waste plastic and refinery waste, refinery residue, coal tar or any type of secondary residue or any type of waste oil wherein a value added useful product is
25 obtained from the waste material .

Accordingly there is provided an improved apparatus consisting of a cylindrical or rectangular cooking vessel (1) heated by electrical heating coils or any other form of energy said vessel is made from stainless steel or mild steel and surrounded by heat reflector & insulator to avoid heat loss & to achieve maximum heating inside locked at
30 the top Lid (2) with temperature sensor which extended upto the centre of the vessel; the

other end protruding outside is connected to a controlled unit by means of wiring; said lid is provided with high temperature gasket for locking by means of lock & bolt; said coking vessel is provided at its side an outlet vent to connect condensing section / condenser (10) the other end of the condenser is connected to the receiving section; 5 said condenser is provided with outer jacket for circulating cold water or thermic fluid from the bottom (11) as & when required for the conversion of gaseous form of product in to liquid state; the said condenser is connected to the receiving assembly / unit (12) by means of suitable conduit (13) in tandem with other receiving units (14) or gasometer (15) and a outlet vent towards the gas collecting and sealing units (16) said 10 receiving unit is maintained at a temperature $[-]40^{\circ}$ to room temperature or higher to collect the distillate in batches or continuously.

DESCRIPTION OF INVENTION

The invention will now be clearly described with figure 1 in the accompanying drawing :

Figure 1 is a prospective view of the improved apparatus

15 Referring to figure 1 provided an improved apparatus consisting of a cylindrical rectangular a coking vessel (1) heated by electrical heating coils or any other form of energy said vessel is made from stainless steel or mild steel and (surrounded by heat reflector & insulator to avoid heat loss & to achieve maximum heating inside) locked at the top (2) with temperature sensor which extended upto the center of the vessel; the 20 other end protruding outside is connected to a controlled unit by means of wiring; said lid is provided with high temperature gasket for locking by means of lock & bolt; said coking vessel is provided at its side an outlet vent to connect condensing section / condenser (10) the other end of the condenser is connected to the receiving section; said condenser is provided with outer jacket for circulating cold water or thermic fluid 25 from the bottom (11) as & when required for the conversion of gaseous form of product into liquid state; the said condenser is connected to the receiving assembly / unit (12) by means of suitable conduit (13) in tandem with other receiving units (14) or gasometer (15) and a outlet vent towards the gas collecting & sealing units (16) said receiving unit is maintained at a temperature $[-]40^{\circ}$ to room temperature or higher to collect the distillate 30 in batches or continuously.

RAW MATERIAL

Any type of waste Plastic (like Polypropylene, Low Density Polyethylene, High Density Polyethylene or any other plastic or combination of them)

Refinery Waste or Refinery Residue or Coal tar or any type of Bitumen or any type of Secondary Residue, or any type of Waste Oil.

5 **ADDITIVES / ADDITIONAL CHEMICALS**

Acidic Chemical like Alumina or any form of Aluminium or Neutral additive like Benzoquinon having concentration in the range of 0.001% to 5.0% depending upon the type of Refinery waste & type of waste plastic.

EQUIPMENT

10 Equipment is assembled in mainly three units.

1. Coking Chamber / Coking Section
2. Condenser / Condensing Section
3. Receiving Unit / Receiving Section

15 With an Electronic / Electrical device to Control and Monitor the Temperature within the coking chamber / section.

1. **COKING CHAMBER / SECTION:**

- Made up of Stainless Steel or Mild Steel or Combination of them.
Thickness of the material is in proportion of size of the Coker and to withstand the heavy temperature.
- 20 - Shape: Cylindrical or Rectangular. If Cylindrical, diameter 9 cm ($\pm 15\%$) or in proper / viable proportion of the mentioned diameter for the purpose of industrial or commercial utilisation. Having height 30 cm ($\pm 20\%$) or in proper / viable proportion of the mentioned height for the purpose of industrial or commercial utilisation. If Rectangular, then having sides ad- measuring 8cm ($\pm 15\%$) each or in proportion of 8 cm and height of 30 cm (\pm
25 15%) or in proportion of 30 cm for the purpose of industrial or commercial utilisation.
- An Air-tight lid is provided.

- One Vent of 2 cm ($\pm 15\%$) diameter or in proportion of the mentioned size coking chamber still at the upper side of coking chamber is provided which can be exactly fitted to a condensing system / device via Mild steel or Stainless Steel Tube.

An arrangement/ provision to raise the temperature of the coking chamber is made. The heating of the coking chamber can be done so as to raise the Temperature up to 600°C. Heating is done Electrically or by any other suitable energy source. Complete coking chamber is given proper insulation to minimise heat loss.

2. CONDENSER / CONDENSING SECTION:

A Condenser is made up of Stainless Steel or Mild Steel or Glass or any other material which does not react with distillate.

It is made up of two concentric tubes of material mentioned above having diameter of 2 cm ($\pm 15\%$) or in proportion of the mentioned size and 6 cm ($\pm 15\%$) or in proportion of the mentioned size respectively.

An arrangement for circulation of water or any Thermic Fluid through the outer tube is designed in such manner in order to condense the product vapours at initial stage and to raise the temperature at latter stage to avoid chocking due to waxy material in the inner tube of condenser.

3. RECEIVING ASSEMBLY:

Outlet of the condenser device is connected to the receiving assembly made up of Stainless Steel or Mild Steel or Glass or any other material which does not react with the distillate to collect the total distillate formed.

An arrangement is made to measure the volume & rate of flow of distillate, continuously or intermittently at any point of time.

This receiving assembly can be cooled down by suitable cooling device up to $[-]20^{\circ}\text{C}$ or it can be heated up to 100°C , as and when required. This receiving container is provided with outlet vent for exit of Coker Gases which can be collected and utilised.

Received Liquid or gas fuels can be partially utilised to raise the temperature of coking chamber/section. Thus at such stage the full process and apparatus runs without any outside energy.

OVERALL SCHEMATIC DIAGRAM OF EQUIPMENT

5 The principle object of this invention is therefore to provide an improved process for the utilization and conversion of waste plastic into usable product such as petrol / kerosene / diesel / furnace oil / lubricating oil fractions / petroleum gases & coke. All are usable products that too without any waste or hazardous by-products.

10 Still further object of this invention is to provide an improved process for manufacturing of Petrol / Kerosene/ diesel/ furnace oil/ lubricating oil fractions, Petroleum gases and coke from any type of waste plastic and refinery waste, refinery residue, coal tar or any type of secondary residue or any type of waste oil to obtain higher yield of distillates at controlled temperature.

15 Still further an improved process for manufacturing of Petrol / Kerosene/ diesel/ furnace oil/ lubricating oil fractions, Petroleum gases and coke from any type of waste plastic and refinery waste, refinery residue, coal tar or any type of secondary residue or any type of waste oil to provide an improved apparatus consisting of coking chamber / coking section,, condenser / condensing section , receiving unit receiving section with an electronic / electrical device to control & monitor the temperature within the coking & other
20 sections to achieve higher yields of distillate with high purity thereby cost effective, safe and user friendly.

Still further object of this invention is to provide an improved process for manufacturing of Petrol / Kerosene/ diesel/ furnace oil/ lubricating oil fractions, Petroleum gases and coke from any type of waste plastic and refinery waste, refinery residue, coal tar or any type of
25 secondary residue or any type of waste oil wherein a value added useful product is obtained from the waste material .

EXAMPLE 1:

After ensuring that the coking chamber/ still is cleaned from inside, about 250 to 500 grams of feed (combination of raw material chemical A and B in different ratios ranging 1:3, 1:1, 3:1 or
30 other proportions/ratios) is accurately weighed and put inside the coking still. Additives

mentioned are added. The lid of the still is tightened with flanges in order to avoid any leakage. An additional gasket is also provided for the same purpose. After setting the unit as already described, heating of coking chamber/still and circulation of water/ thermic fluid is started. The temperature within the condenser is lowered by circulation of chilled water/ thermic coolant for
5 condensation of vapours coming out of coking chamber. The heating process of coking chamber is well controlled and can be either slower or accelerated at any moment. The time of first drop of distillate coming is noted properly along with corresponding Temperature reading. Towards the end, the waxy material may come. So to keep distillate in liquid state, hot water/Thermic fluid is circulated through the condenser tube in latter stage. In the beginning the distillate evolution is
10 more and reaches maximum and then the rate of distillate evolution falls and the rate of gas evolution increases. Then, the distillate evolution stops, finally the gas evolution also stops, and a final 30 minutes heating is required for the completion of coking.

Then, the heating is stopped and the coking still is allowed to cool to the room temperature. After cooling, coking still is opened and coke inside the still is taken out and collected. The amount of
15 coke formed is established by weighing. The volume of distillate formed with time was noted. And then the amount of total distillate & gases formed are also found out.

The total distillate collected is transferred to a flask. First this total distillate was analyzed for important properties like specific gravity, viscosity (Kinematic or Redwood), aniline point, refractive index etc. Next the ASTM distillation of total distillate was carried out and different
20 fractions namely fraction I - IBP-140°C (Light Naphtha cut), Fraction II- 140°C- 200°C (Heavy Naphtha and gasoline component), fraction III - 200°C-250°C (kerosene fraction), fraction IV – above 250°C (Diesel Fractions furnace oil / Lubricating Oil were collected).

From these by blending fraction I (IBP-140°C) and fraction II (140-200°C) full range motor Gasoline fraction (IBP – 200°C) is made. By blending fraction II (140-200°C) and fraction III
25 (200-250°C) a new full range kerosene fraction (140-250°C) is made which is tested for kerosene. Fraction IV above (250°C) is tested for high-speed diesel, furnace oil & Lubricating oil.

Different properties namely specific gravity, viscosity, aniline point and refractive index of each of these fractions were determined by BIS/IP/ASTM methods. The proximate analysis of the
30 petroleum coke formed was also found out as per BIS standards.

This is an embodiment of the invention. Several modifications are possible may be considered within the ambit and spirit of this invention. Since many modifications, variations and changes in detail may be made to the above described embodiments, it is intended that all matters described in the foregoing description as described in the accompanying specifications.

CLAIMS

1. An improved process of manufacturing petrol / kerosene / diesel from refinery waste and waste plastic with additives comprising of the following steps :
 - 5 i. Charging the waste plastic and waste refinery in the ratio 1-90% : 99 – 10% along with 0.01 to 5% of additives in the reactor maintained at room temperature;
 - ii. Heating the reactor up to 600^oC with in 1- 5 hrs as per the requirements;
 - iii. maintaining the temperature at any particular level depending upon the reactant;
 - iv. Condensing the vapour phase by circulating coolants, chilled water or thermic fluid;
 - v. Receiving the distillate in the receiving section maintained at – 40^oC room temperature;
 - 10 vi. Fractional distilling of the various components of distillate at its required IBP ranges by a batch method or continuous;
 - vii. Sealing the petroleum gas through gasometer in various containers as per the market demand / requirements;
 - viii. Collecting residual coke from the reactor an important ingredient used by electronic
15 industries, chemical industries and many others.
2. An improved apparatus consisting of a cylindrical¹rectangular coking vessel (1) heated by electrical heating coils or any other form of energy said vessel is made from stainless steel or mild steel and surrounded by heat reflector and insulator to avoid heat loss and to achieve maximum heating inside locked at the top (2) with temperature sensor which
20 extended upto the center of the vessel; the other end of the sensor protruding outside is connected to a controlled unit by means of wiring; said lid is provided with high temperature gasket for locking by means of lock and bolt; said coking vessel is provided at its side an outlet vent to correct condensing section/ condenser (10) the other end of the condenser is connected to the receiving section; said condenser is provide with outer
25 jacket for circulating cold water or thermic fluid from the bottom (11) as and when

required for the conversion of gaseous form of product into liquid state; the said condenser is connected to the receiving assembly / unit (12) by means of suitable conduit (13) in tandem with other receiving unit (14) or gasometer (15) and an outlet vent towards the gas collecting and sealing unit (16) said receiving unit is maintained at a temperature
5 [-]40°C to room temperature or higher to collect the distillate in batches or continuously.

3. A process as claimed in claim 1 is substantially herein described in example 1 in the specification.
4. An apparatus as claimed in claim 2, and substantially herein described in figures 1 in the accompanying specification.

1/1

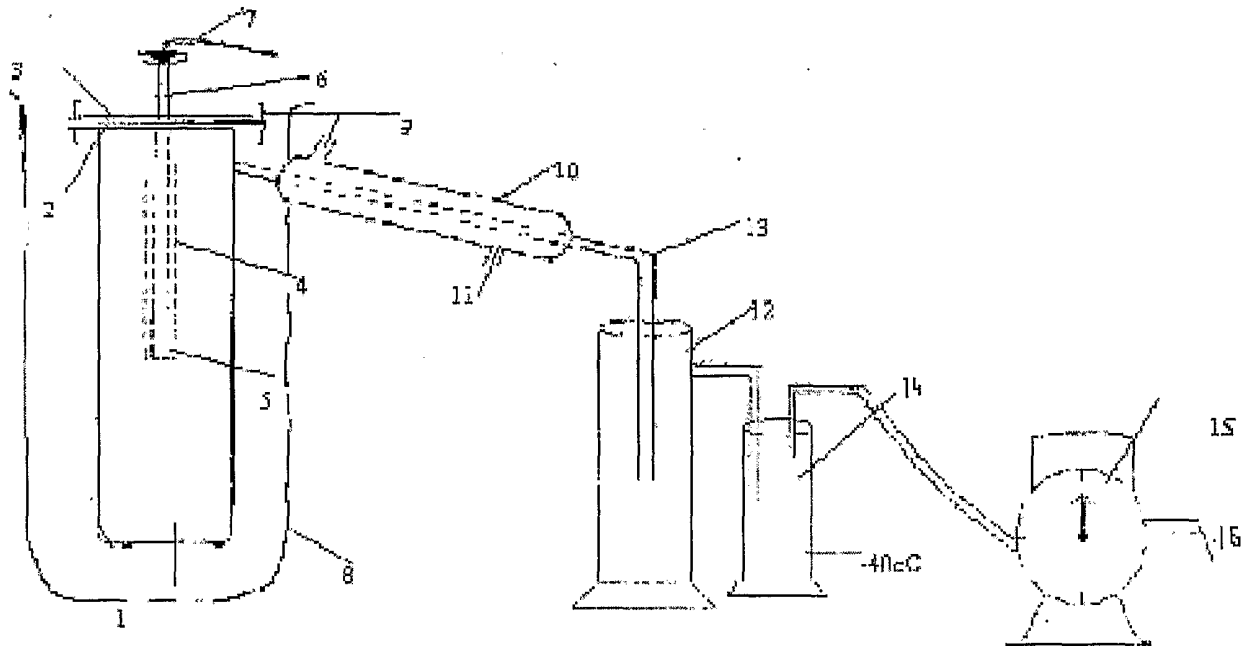

Fig. 1

INTERNATIONAL SEARCH REPORT

International Application No
PCT/IN 01/00061

A. CLASSIFICATION OF SUBJECT MATTER
IPC 7 C10G1/10 C10G1/02 C10B53/00

According to International Patent Classification (IPC) or to both national classification and IPC

B. FIELDS SEARCHED
Minimum documentation searched (classification system followed by classification symbols)
IPC 7 C10G C10B

Documentation searched other than minimum documentation to the extent that such documents are included in the fields searched

Electronic data base consulted during the international search (name of data base and, where practical, search terms used)
EPO-Internal, WPI Data

C. DOCUMENTS CONSIDERED TO BE RELEVANT

Category °	Citation of document, with indication, where appropriate, of the relevant passages	Relevant to claim No.
A	DATABASE WPI Section Ch, Week 200015 Derwent Publications Ltd., London, GB; Class A35, AN 2000-161729 XP002189916 & CN 1 236 804 A (YANG J), 1 December 1999 (1999-12-01) abstract	1,2
A	US 5 584 969 A (HAMA TOSHIO ET AL) 17 December 1996 (1996-12-17) claims 1,7	1,2

Further documents are listed in the continuation of box C. Patent family members are listed in annex.

° Special categories of cited documents :

- *A* document defining the general state of the art which is not considered to be of particular relevance
- *E* earlier document but published on or after the international filing date
- *L* document which may throw doubts on priority claim(s) or which is cited to establish the publication date of another citation or other special reason (as specified)
- *O* document referring to an oral disclosure, use, exhibition or other means
- *P* document published prior to the international filing date but later than the priority date claimed
- *T* later document published after the international filing date or priority date and not in conflict with the application but cited to understand the principle or theory underlying the invention
- *X* document of particular relevance; the claimed invention cannot be considered novel or cannot be considered to involve an inventive step when the document is taken alone
- *Y* document of particular relevance; the claimed invention cannot be considered to involve an inventive step when the document is combined with one or more other such documents, such combination being obvious to a person skilled in the art.
- *&* document member of the same patent family

Date of the actual completion of the international search 11 February 2002	Date of mailing of the international search report 01/03/2002
---	--

Name and mailing address of the ISA European Patent Office, P.B. 5818 Patentlaan 2 NL - 2280 HV Rijswijk Tel. (+31-70) 340-2040, Tx. 31 651 epo nl, Fax: (+31-70) 340-3016	Authorized officer De Herdt, O
--	---------------------------------------

INTERNATIONAL SEARCH REPORT

Information on patent family members

International Application No

PCT/IN 01/00061

Patent document cited in search report		Publication date	Patent family member(s)	Publication date
CN 1236804	A	01-12-1999	NONE	
US 5584969	A	17-12-1996	JP 2876276 B2	31-03-1999
			JP 7041773 A	10-02-1995
			JP 2604313 B2	30-04-1997
			JP 7041775 A	10-02-1995
			JP 2622934 B2	25-06-1997
			JP 7048575 A	21-02-1995
			JP 3018027 B2	13-03-2000
			JP 7166171 A	27-06-1995
			JP 2905956 B2	14-06-1999
			JP 7305076 A	21-11-1995
			AT 174052 T	15-12-1998
			CA 2129049 A1	30-01-1995
			DE 69414926 D1	14-01-1999
			DE 69414926 T2	27-05-1999
			DK 636674 T3	16-08-1999
			EP 0636674 A1	01-02-1995
			KR 140957 B1	15-06-1998
			KR 140899 B1	15-06-1998
			US 5597451 A	28-01-1997