



(19) **United States**

(12) **Patent Application Publication**
KOENEMAN et al.

(10) **Pub. No.: US 2017/0130350 A1**
(43) **Pub. Date: May 11, 2017**

(54) **SIGNAL GENERATION SYSTEM FOR A HYDROGEN GENERATION SYSTEM**

(60) Provisional application No. 62/091,702, filed on Dec. 15, 2014.

(71) Applicants: **ROBERT LOUIS KOENEMAN**,
CAPE CANAVERAL, FL (US);
TRAVER HALL KENNEDY, CAPE
CANAVERAL, FL (US)

Publication Classification

(51) **Int. Cl.**
C25B 15/02 (2006.01)
C25B 1/04 (2006.01)
(52) **U.S. Cl.**
CPC **C25B 15/02** (2013.01); **C25B 1/04**
(2013.01)

(72) Inventors: **ROBERT LOUIS KOENEMAN**,
CAPE CANAVERAL, FL (US);
TRAVER HALL KENNEDY, CAPE
CANAVERAL, FL (US)

(73) Assignee: **JOI SCIENTIFIC, INC.**, MERRITT
ISLAND, FL (US)

(57) **ABSTRACT**

(21) Appl. No.: **15/157,398**

A hydrogen generation method includes generating a driver signal wherein the driver signal is a pulsed DC signal, processing the driver signal to generate a chamber excitation signal and applying the chamber excitation signal to a hydrogen generation chamber to generate hydrogen from a feedstock contained within the chamber wherein the hydrogen generation chamber includes at least one hollow cylindrical anode configured to contain the feedstock, and at least one cathode positioned within the at least one hollow cylindrical anode.

(22) Filed: **May 17, 2016**

Related U.S. Application Data

(63) Continuation-in-part of application No. 14/852,744, filed on Sep. 14, 2015, now Pat. No. 9,340,885, which is a continuation-in-part of application No. 14/616,851, filed on Feb. 9, 2015.

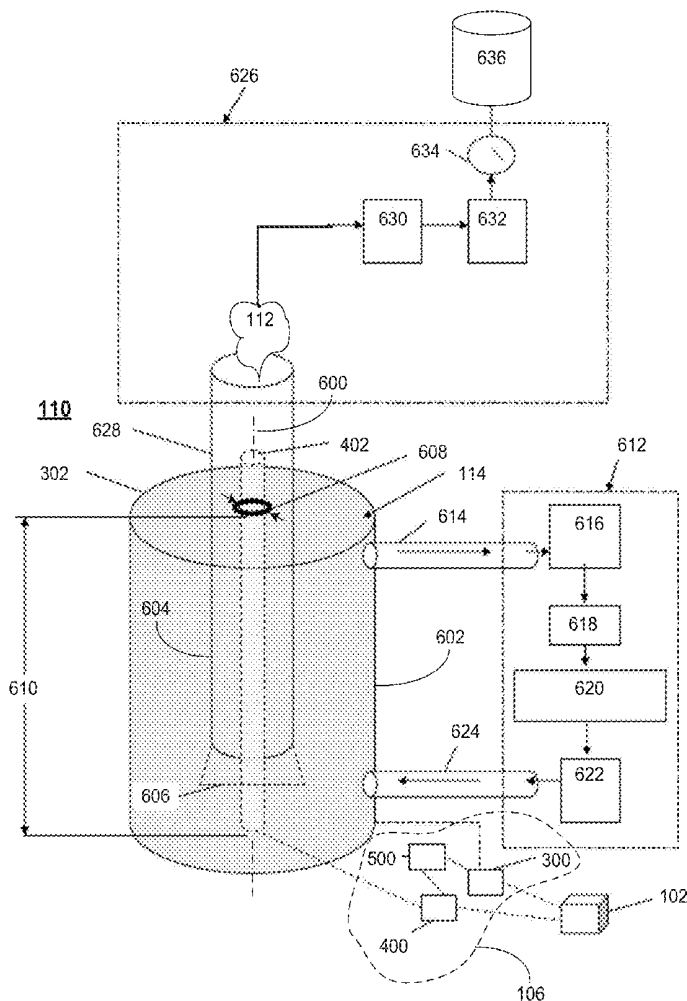

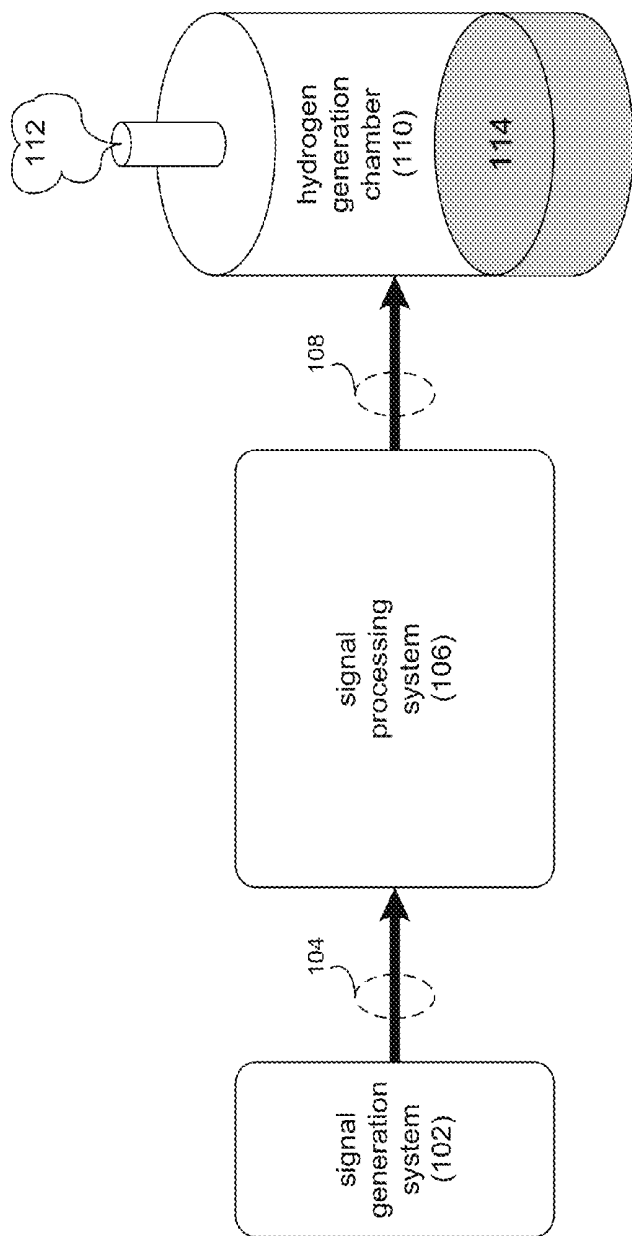

100

FIG. 1

102

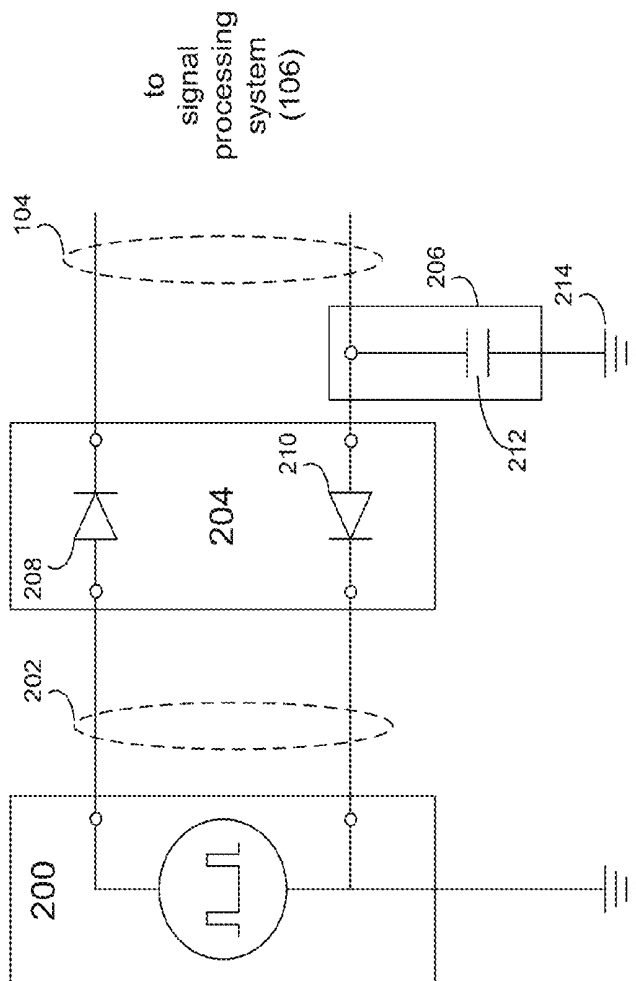

FIG. 2

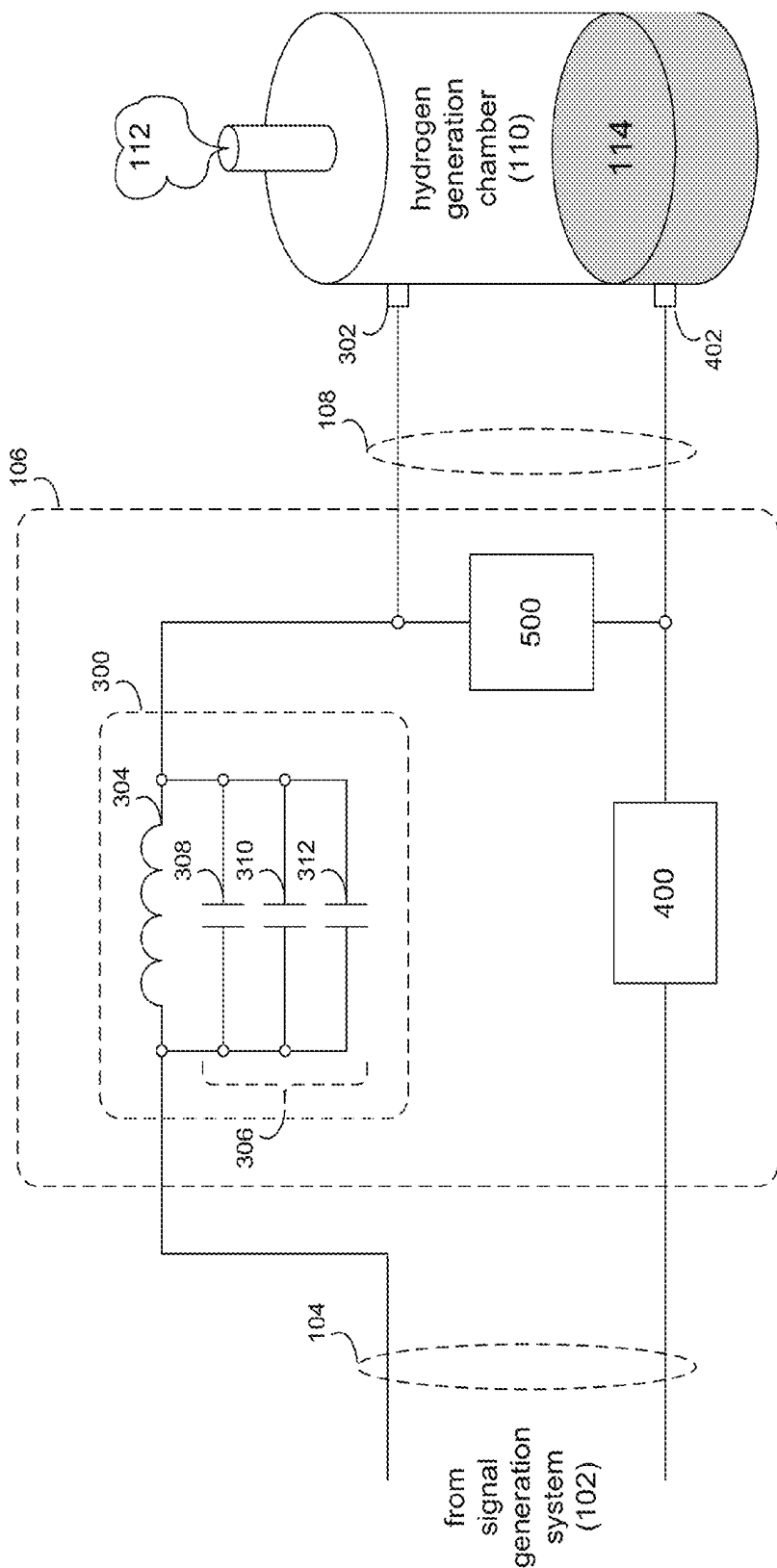

FIG. 3

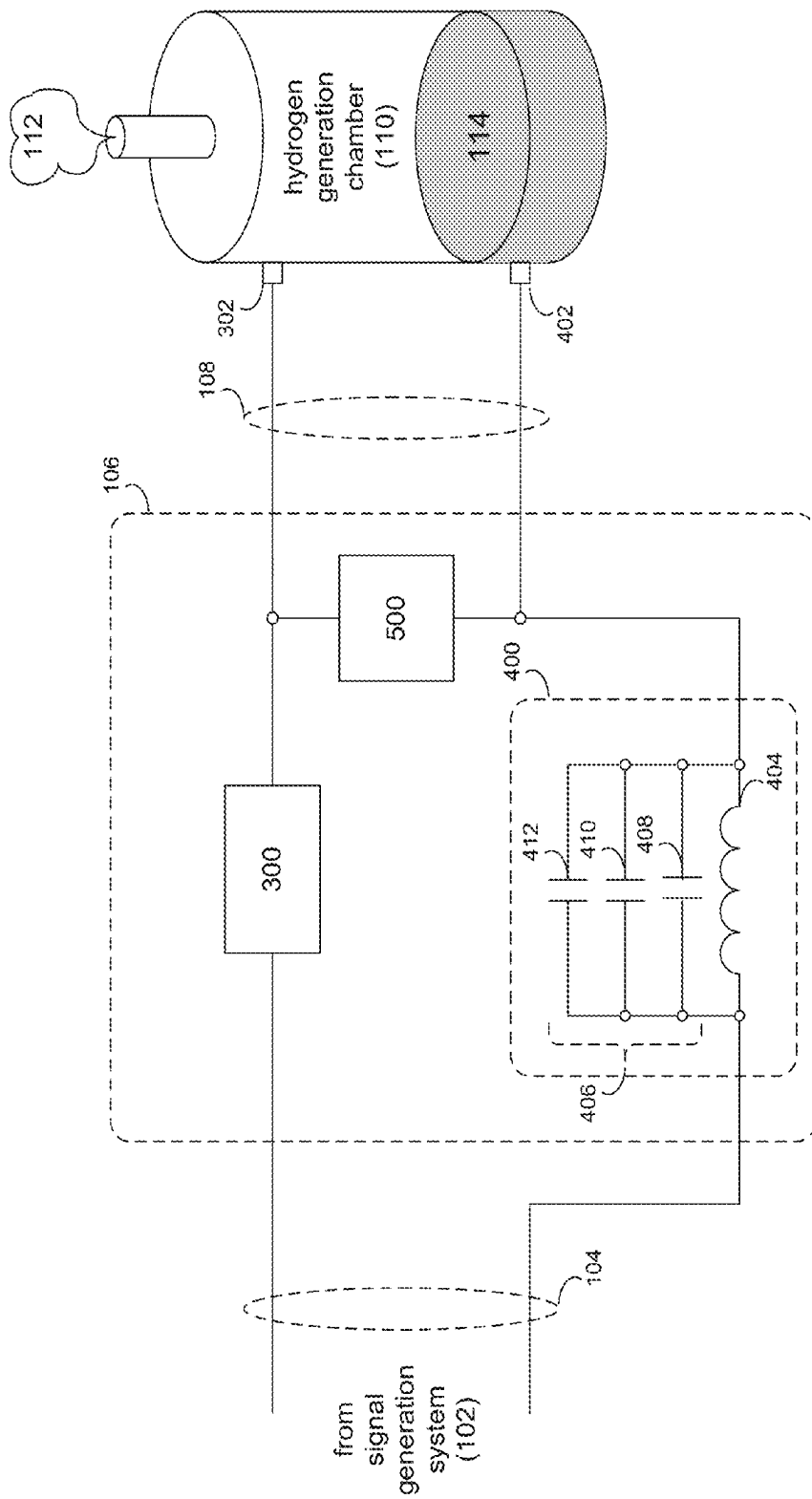

FIG. 4

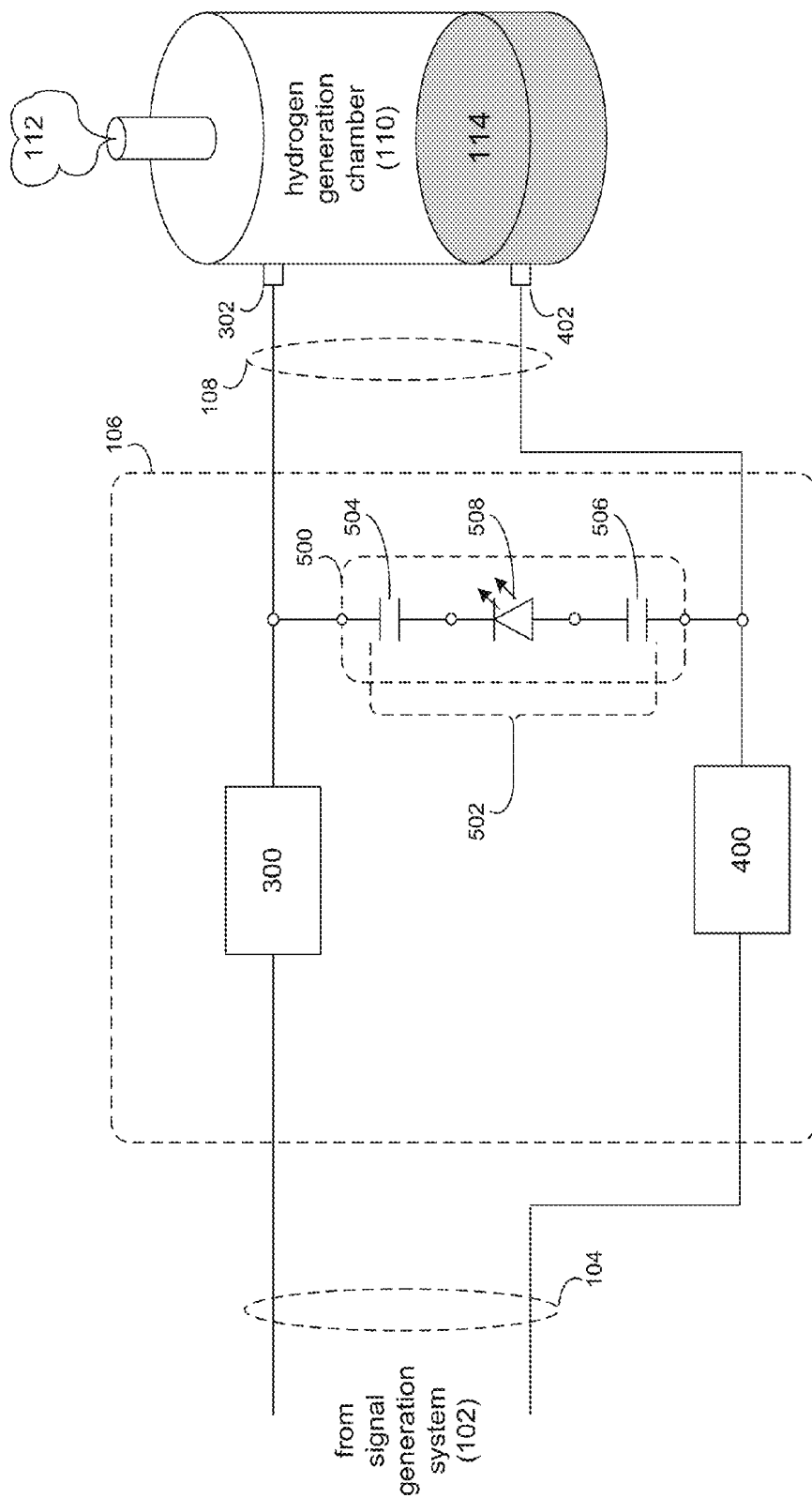

FIG. 5

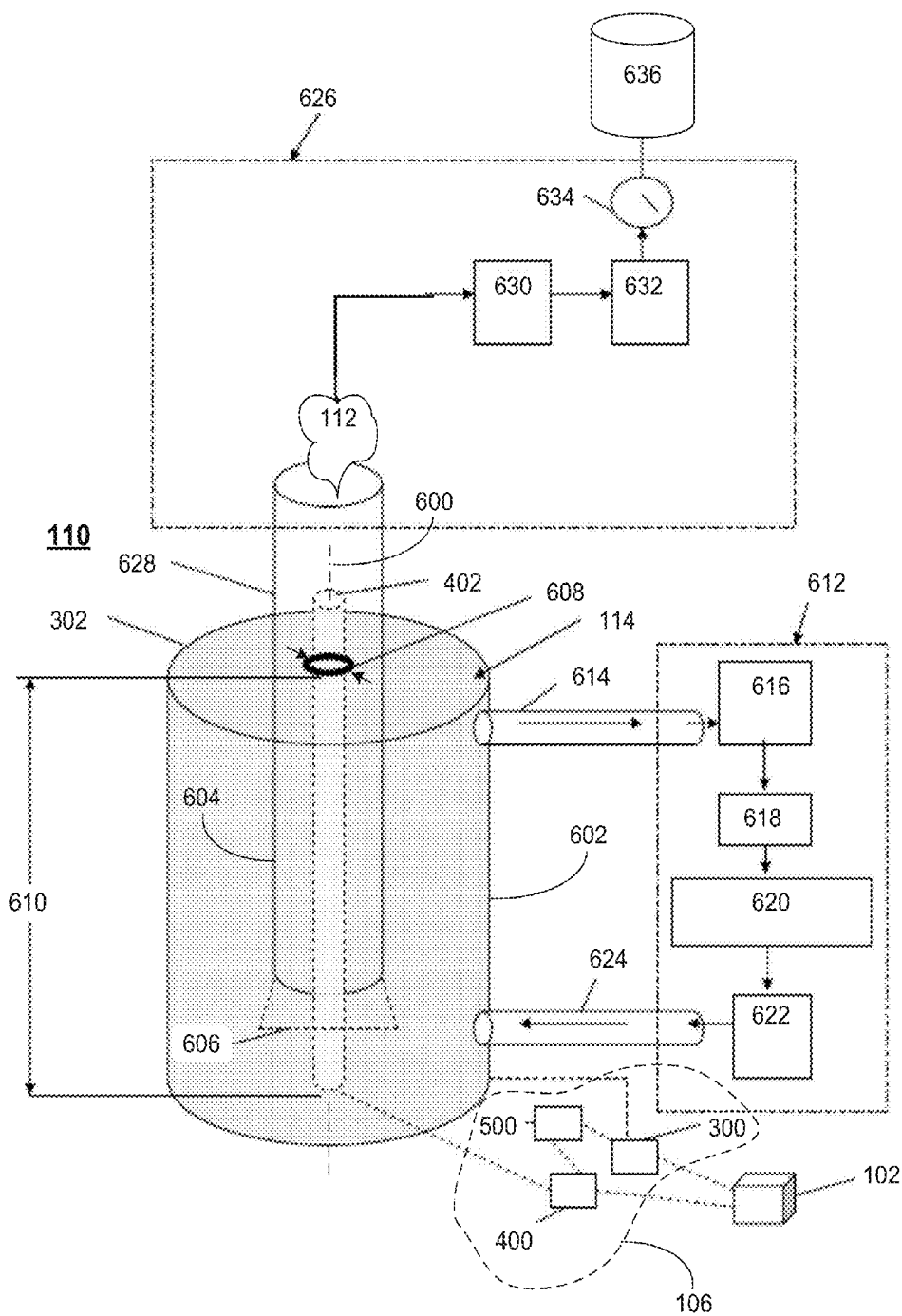

FIG. 6

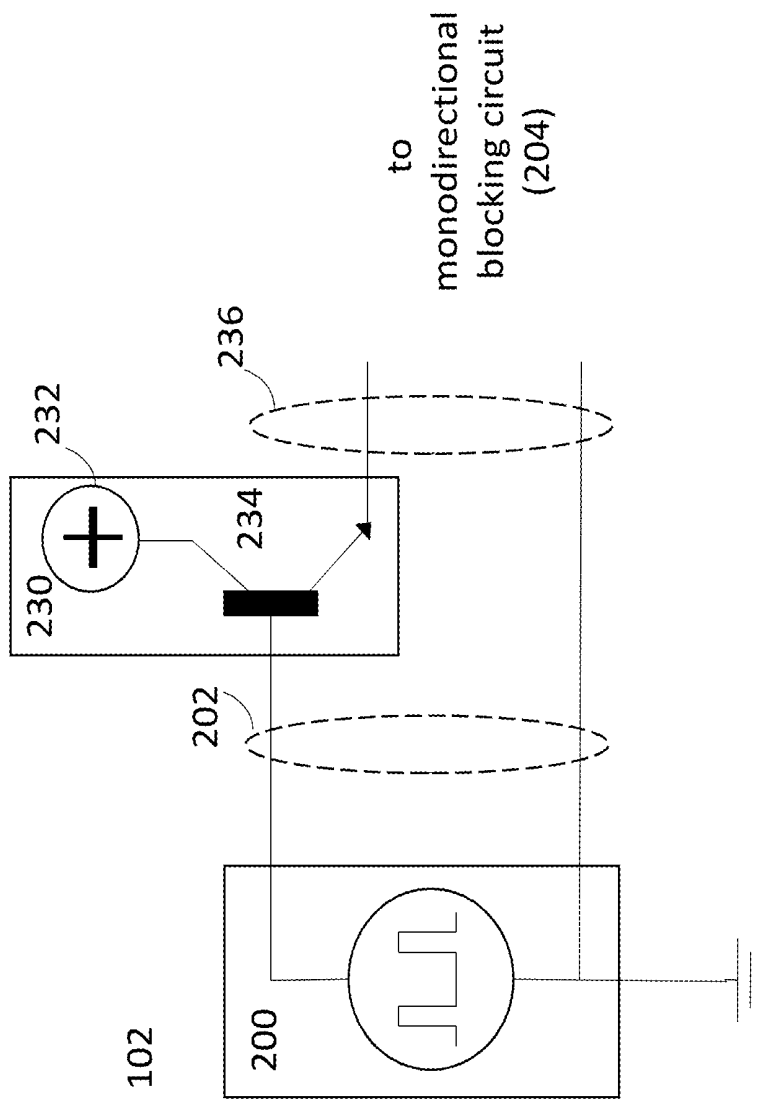

Fig. 7

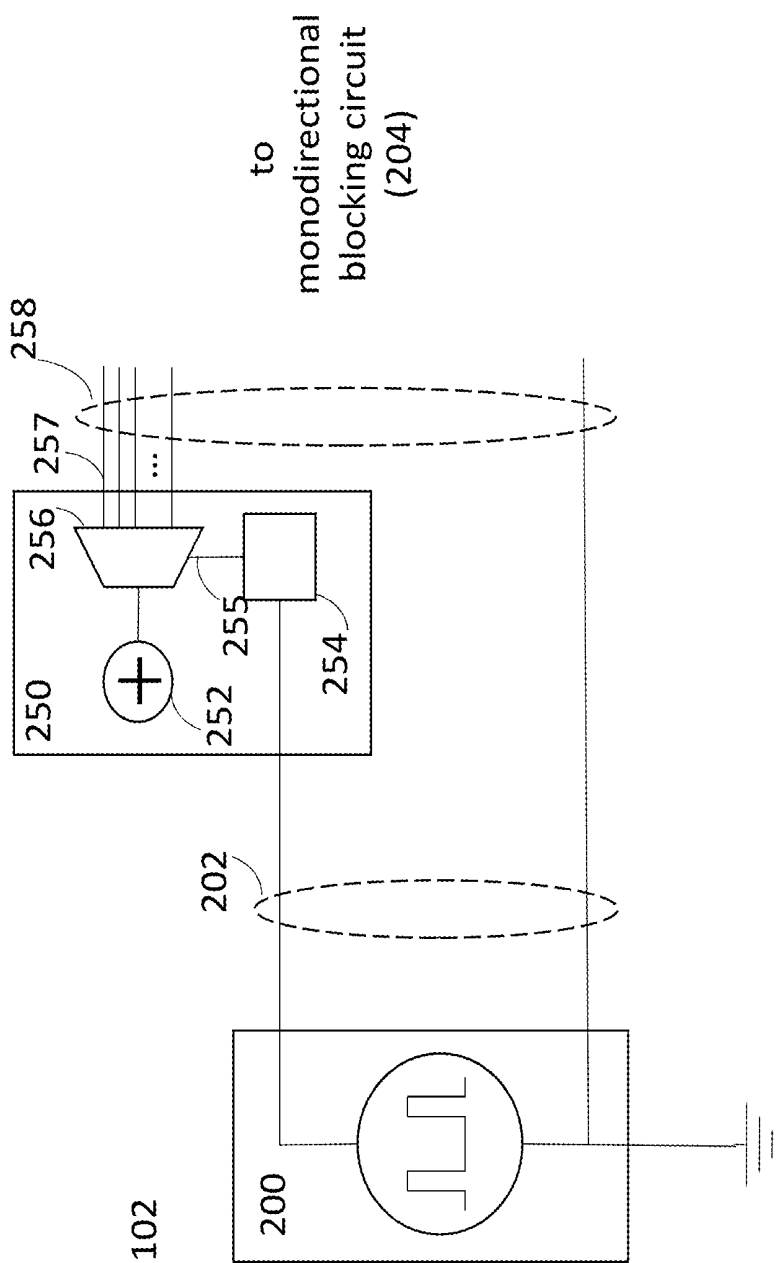

Fig. 8

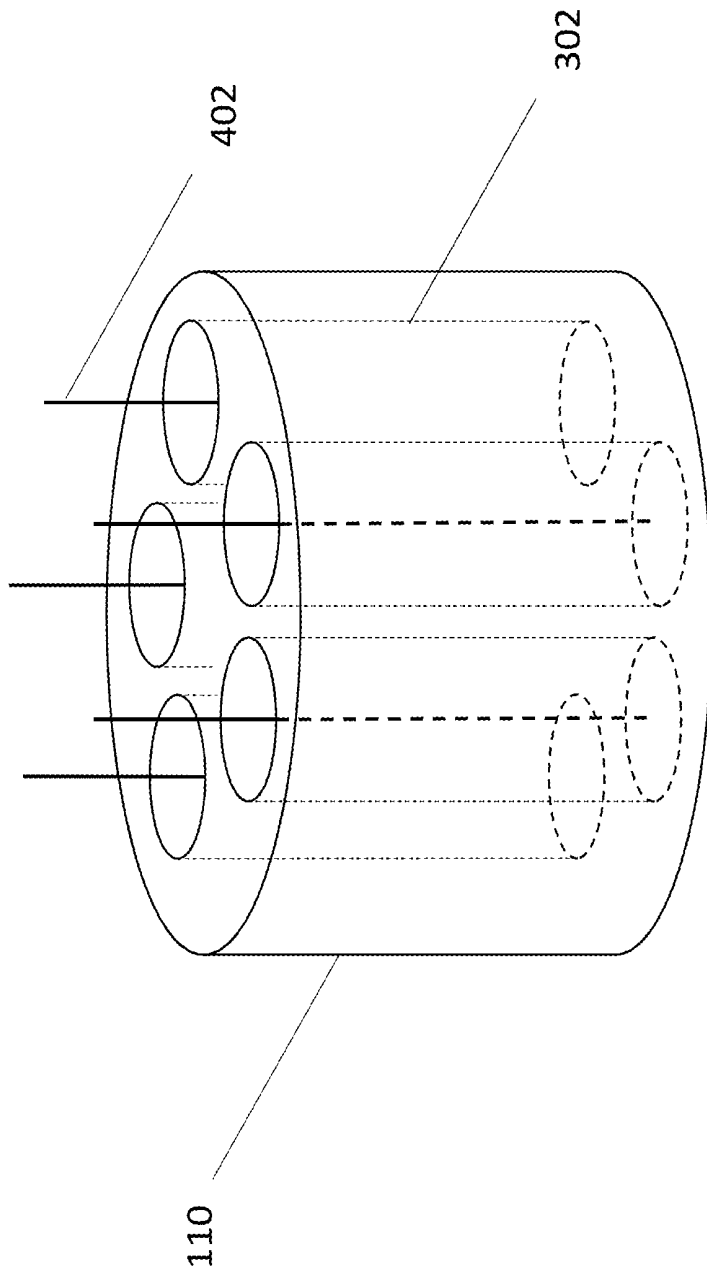

Fig. 9

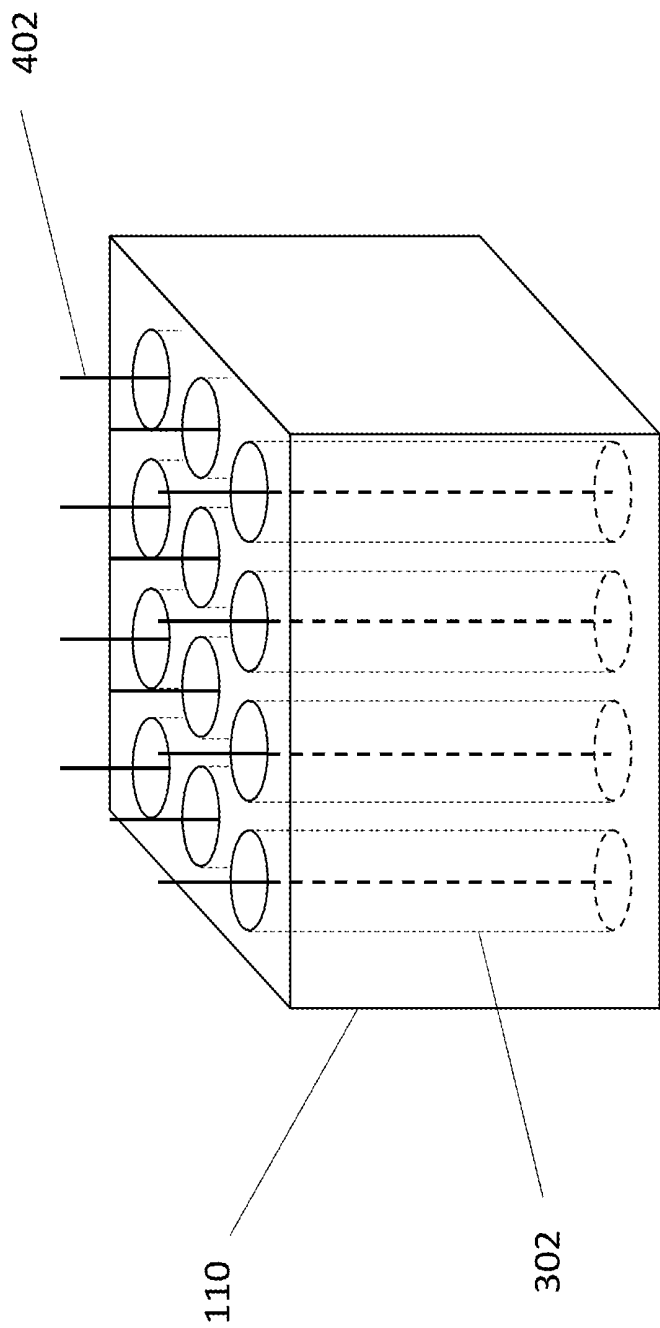

Fig. 10

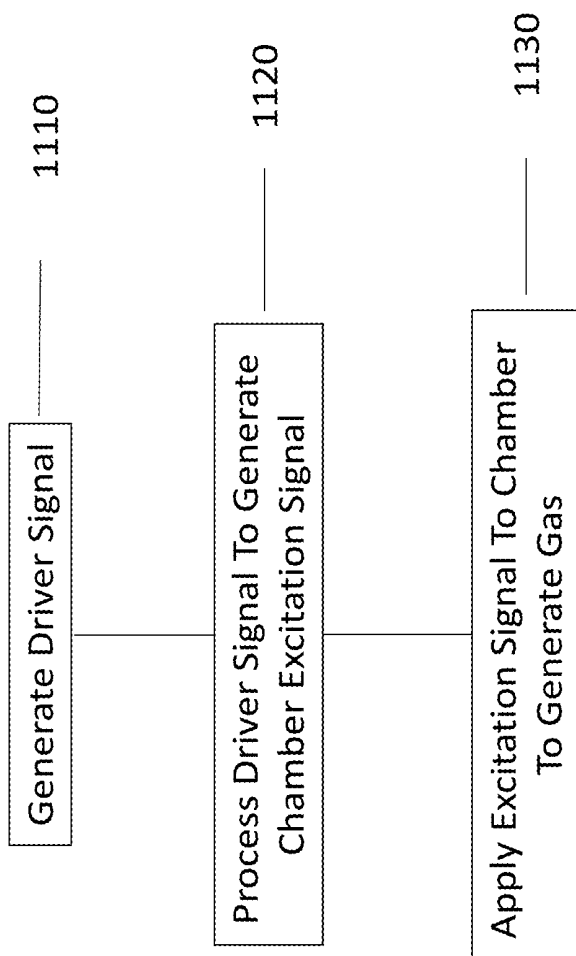

Fig. 11

SIGNAL GENERATION SYSTEM FOR A HYDROGEN GENERATION SYSTEM

RELATED APPLICATION(S)

[0001] This application claims the benefit of U.S. Provisional Patent Application No. 62/091,702, entitled Polyphonic Methods and Related Apparatus and Arrangements and filed on 15 Dec. 2014, the entire contents of which is herein incorporated by reference.

[0002] This application is a Continuation-in-Part (CIP) of each of the following U.S. Utility patent application Ser. No. 14/616,851, entitled Energy Extraction System and Methods and filed on 09 Feb. 2015; Ser. No. 14/852,695 entitled Hydrogen Generation System filed on 14 Sep. 2015; Ser. No. 14/852,715 entitled Hydrogen Generation Chamber For A Hydrogen Generation System filed on 14 Sep. 2015; Ser. No. 14/852,732 entitled Feedback Circuit For A Hydrogen Generation System filed on 14 Sep. 2015; Ser. No. 14/852,744 entitled Negative Reactive Circuit For A Hydrogen Generation System filed on 14 Sep. 2015; Ser. No. 14/852,769 entitled Positive Reactive Circuit For A Hydrogen Generation System filed on 14 Sep. 2015; and Ser. No. 14/852,785 entitled Signal Generation System For A Hydrogen Generation System filed on 14 Sep. 2015. The entire contents of each of these applications are herein incorporated by reference.

TECHNICAL FIELD

[0003] This disclosure relates to hydrogen generation systems and, more particularly, to hydrogen generation systems that use hydrolysis to generate hydrogen from feedstock.

BACKGROUND

[0004] Currently, the majority of the energy consumed by the developed world has its origins in fossil fuels. Unfortunately, there are many well-documented problems associated with over-reliance upon energy generated from fossil fuels, such as: pollution and climate change caused by the emission of greenhouse gases; the finite nature of fossil fuels and the dwindling reserves of such carbon-based energy sources; and the concentration of control of petroleum-based energy supplies by various volatile countries and OPEC.

[0005] Accordingly, there is a need for alternative sources of energy. One such alternative energy source includes hydrogen generation systems that produce hydrogen via hydrolysis. Ideally, such hydrogen generation systems would be capable of producing hydrogen gas without the presence of oxygen, wherein such hydrogen may be used for industrial, commercial and residential purposes.

[0006] For example, when greater than 99% pure, hydrogen may be used in generator cooling, steel production, glass production, and semiconductor and photovoltaic cell production. When less than 99% pure, hydrogen may be used in various industries, such as the aerospace industry, the animal feed industry, the automotive industry, the baking industry, the chemical industry, the ethanol industry, the food processing industry, the dairy industry, the meat industry, the manufacturing industry, the medical industry, the hospitality industry, the laundry/uniform industry, the marine and off-shore industry, the military and defense industry, the mining industry, the oil and gas industry, the paper/corrugating industry, the pharmaceutical industry, the rubber industry,

the steel and metals industry, the tobacco industry, the transportation industry, the wire and cable industry, and the education industry.

[0007] Unfortunately, there are a number of significant hurdles that prevent the widespread use of hydrogen in commercial, industrial, and residential applications. These hurdles include cost, efficiency, and safety. First and foremost, creating hydrogen gas in a traditional manner is inefficient and costly, or even environmentally harmful when produced via reformation (i.e., the primary commercial method). Secondly, hydrogen's very low mass and energy density makes it challenging to get enough mass of hydrogen gas safely in one place to be of practical value to a user. The result is that hydrogen has been prohibitively expensive to produce, compress, cryogenically cool, maintain (at pressure and temperature), contain (due to its very small molecule structure), and transport. Accordingly, pressure, temperature, flammability, explosiveness, and low ignition energy requirement are all significant safety issues concerning the widespread use of hydrogen.

SUMMARY OF DISCLOSURE

[0008] In one implementation, a hydrogen generation system includes a signal generation system configured to generate a driver signal. A signal processing system is configured to process the driver signal and generate a chamber excitation signal. A hydrogen generation chamber is configured to receive the chamber excitation signal and generate hydrogen from a feedstock contained within the hydrogen generation chamber. The driver signal is a pulsed DC signal.

[0009] One or more of the following features may be included. The signal generation system may include a pulsed DC source configured to generate a pulsed DC source signal, a mono-directional blocking circuit configured to receive the pulsed DC source signal and generate the driver signal, and a filter circuit configured to filter the driver signal and remove AC components. The mono-directional blocking circuit may include at least one asymmetrically conductive component. The at least one asymmetrically conductive component may include a Schottky diode. The mono-directional blocking circuit may include two asymmetrically conductive components. The filter circuit may include a capacitor coupled to ground. The driver signal may have a duty cycle of less than 25%. The driver signal may have a duty cycle between 1% and 13%. The driver signal may have a frequency of between 100 hertz and 10 kilohertz.

[0010] In another implementation, a hydrogen generation system includes a signal generation system configured to generate a driver signal. A signal processing system is configured to process the driver signal and generate a chamber excitation signal. A hydrogen generation chamber is configured to receive the chamber excitation signal and generate hydrogen from a feedstock contained within the hydrogen generation chamber. The signal generation system includes: a pulsed DC source configured to generate a pulsed DC source signal, a mono-directional blocking circuit configured to receive the pulsed DC source signal and generate the driver signal, the mono-directional blocking circuit including at least one asymmetrically conductive component, and a filter circuit configured to filter the driver signal and remove AC components.

[0011] One or more of the following features may be included. The at least one asymmetrically conductive component may include a Schottky diode. The mono-directional

blocking circuit may include two asymmetrically conductive components. The filter circuit may include a capacitor coupled to ground. The driver signal may have a duty cycle of less than 25%. The driver signal may have a duty cycle between 1% and 13%.

[0012] In another implementation, a hydrogen generation system includes a signal generation system configured to generate a driver signal. A signal processing system is configured to process the driver signal and generate a chamber excitation signal. A hydrogen generation chamber is configured to receive the chamber excitation signal and generate hydrogen from a feedstock contained within the hydrogen generation chamber. The signal generation system includes: a pulsed DC source configured to generate a pulsed DC source signal, a mono-directional blocking circuit, including at least one asymmetrically conductive component, configured to receive the pulsed DC source signal and generate the driver signal, and a filter circuit, including a capacitor coupled to ground, configured to filter the driver signal and remove AC components.

[0013] One or more of the following features may be included. The mono-directional blocking circuit may include two asymmetrically conductive components. The driver signal may have a duty cycle of less than 25%. The driver signal may have a duty cycle between 1% and 13%. The driver signal may have a frequency of between 100 hertz and 10 kilohertz.

[0014] In another implementation, a hydrogen generation system includes a signal generation system configured to generate a first driver signal. A switching system is configured to process the first driver signal and activate a power generation system to generate a second driver signal. A signal processing system is configured to process the second driver signal and generate a chamber excitation signal. A hydrogen generation chamber is configured to receive the chamber excitation signal and generate hydrogen from a feedstock contained within the hydrogen generation chamber. The first driver signal is a pulsed DC signal. The second driver signal is a pulsed DC signal.

[0015] One or more of the following features may be added. The switching system includes: a power generation system configured to supply power with a voltage that may be different from that of the signal generation system; and a switch that may be activated by the first driver signal to create a second driver signal, the second driver signal having the same frequency and duty cycle of the first driver signal and voltage of the power generation system. The first driver signal and second driver signal may have a duty cycle of less than 25%. The first driver signal and second driver signal may have a duty cycle between 1% and 13%. The first driver signal and second driver signal may have a frequency of between 100 hertz and 10 kilohertz.

[0016] In another implementation, a hydrogen generation system includes a signal generation system configured to generate a first driver signal. A selection system is configured to process the first driver signal and activate a power generation system to generate a succession of one or more second driver signals. One or more signal processing systems is configured to process the one or more second driver signals and generate one or more chamber excitation signals. One or more hydrogen generation chambers is configured to receive the one or more chamber excitation signals and generate hydrogen from a feedstock contained within the one or more hydrogen generation chambers. The first driver

signal is a pulsed DC signal. The one or more second driver signals is a pulsed DC signal.

[0017] One or more of the following features may be added. The selection system includes: a counter system configured to receive the first driver signal, increment a counter, generate a counter signal, and reset the counter system after a fixed number of increments; a power generation system configured to supply power with a voltage that may be different from that of the signal generation system; and a demultiplexer configured to receive power from a power generation system and an addressing signal from the counter system and generate a plurality of one or more second driver signals, the one or more second driver signals having the same frequency and duty cycle of the first driver signal and voltage of the power generation system. The first driver signal and second driver signal may have a duty cycle of less than 25%. The first driver signal and second driver signal may have a duty cycle between 1% and 13%. The first driver signal and second driver signal may have a frequency of between 100 hertz and 10 kilohertz.

[0018] The details of one or more implementations are set forth in the accompanying drawings and the description below. Other features and advantages will become apparent from the description, the drawings, and the claims.

BRIEF DESCRIPTION OF THE DRAWINGS

[0019] FIG. 1 is a diagrammatic view of a hydrogen generation system;

[0020] FIG. 2 is a diagrammatic view of a signal generation system included within the hydrogen generation system of FIG. 1;

[0021] FIG. 3 is a diagrammatic view of a positive reactive circuit included within the hydrogen generation system of FIG. 1;

[0022] FIG. 4 is a diagrammatic view of a negative reactive circuit included within the hydrogen generation system of FIG. 1;

[0023] FIG. 5 is a diagrammatic view of a feedback circuit included within the hydrogen generation system of FIG. 1;

[0024] FIG. 6 is a diagrammatic view of a hydrogen generation chamber included within the hydrogen generation system of FIG. 1;

[0025] FIG. 7 is a diagrammatic view of a signal generation system included within the hydrogen generation system of FIG. 1;

[0026] FIG. 8 is a diagrammatic view of a signal generation system included within the hydrogen generation system of FIG. 1;

[0027] FIG. 9 is a diagrammatic view of multiple generation chambers arranged in a cylindrical orientation;

[0028] FIG. 10 is a diagrammatic view of multiple generation chambers arranged in a rectangular orientation; and

[0029] FIG. 11 illustrates a process for generating gas according to an exemplary implementation.

[0030] Like reference symbols in the various drawings indicate like elements.

DETAILED DESCRIPTION OF THE PREFERRED EMBODIMENTS

Hydrogen Generation System Overview

[0031] Referring to FIG. 1, there is shown hydrogenation generation system **100**. Hydrogen generation system **100**

may include signal generation system 102 configured to generate a driver signal 104. An example of driver signal 104 may include but is not limited to a pulsed DC signal. Driver signal 104 may be provided to signal processing system 106, wherein signal processing system 106 may be configured to process driver signal 104 and generate a chamber excitation signal 108.

[0032] Hydrogen generation system 100 may include hydrogen generation chamber 110 that may be configured to receive chamber excitation signal 108 and generate hydrogen 112 (e.g., gaseous hydrogen) from feedstock 114 contained within hydrogen generation chamber 110.

[0033] As discussed above, hydrogen 112 produced by hydrogen generation system 100 may be used with various industries, such as the aerospace industry, the animal feed industry, the automotive industry, the baking industry, the chemical industry, the ethanol industry, the food processing industry, the dairy industry, the meat industry, the manufacturing industry, the medical industry, the hospitality industry, the laundry/uniform industry, the marine and offshore industry, the military, the mining industry, the oil and gas industry, the paper/corrugating industry, the pharmaceutical industry, the rubber industry, the steel and metals industry, the tobacco industry, the transportation industry, the wire and cable industry, and the education industry.

[0034] As discussed above, hydrogen generation system 100 may generate hydrogen 112 (e.g., gaseous hydrogen) from feedstock 114 contained within hydrogen generation chamber 110. One example of feedstock 114 may include but is not limited to sea water. Accordingly and in certain implementations, hydrogen generation system 100 may be positioned proximate a source of feedstock 114. Alternatively, feedstock 114 may be provided to hydrogen generation system 100 via a delivery network, not shown.

[0035] Hydrogen generation chamber 110, when filled with an electrolytic fluid (e.g., feedstock 114), may react like a variable capacitive load with corresponding variable impedance values. When a Pulsed DC signal (e.g., chamber excitation signal 108) is applied to hydrogen generation chamber 110, the result may be a reactive load. Hydrogen generation chamber 110 may complete the closed circuit path that forms the load factor during the ON Cycle Pulse (OCP) of chamber excitation signal 108.

[0036] The electrolytic fluid (e.g., feedstock 114) may change state both chemically and electronically during the OCP of chamber excitation signal 108. These changes may affect the charge state of feedstock 114, changing the above-described capacitive and impedance values, which may be monitored via a differential potential voltage measurement across the anode and cathode of hydrogen generation chamber 110.

[0037] Signal processing system 106 may provide impedance matching and capacitive balancing during the OCP of chamber excitation signal 108. Balancing of signal processing system 106 may accomplish multiple functions, including but not limited to lowering reactive circuit current demand while directing chamber excitation signal 108 with a given base frequency across the electrodes of hydrogen generation chamber 110.

[0038] During the OFF Cycle Pulse (OFCP) of chamber excitation signal 108, the inductive and capacitive sections of signal processing system 106 may receive energy from hydrogen generation chamber 110 as hydrogen generation chamber 110 discharges.

Signal Generation System Configuration

[0039] Referring to FIG. 2, there is shown one implementation of signal generation system 102. Signal generation system 102 may include pulsed DC source 200 configured to generate pulsed DC source signal 202. Signal generation system 102 may include mono-directional blocking circuit 204 configured to receive pulsed DC source signal 202 and generate driver signal 104. Signal generation system 102 may also include filter circuit 206 configured to filter driver signal 104 and remove AC components.

[0040] Mono-directional blocking circuit 204 may include at least one asymmetrically conductive component, an example of which includes but is not limited to a diode (e.g., a Schottky diode), such as a 1N4003G diode available from ON Semiconductor configured to function as blocking diodes. In a typical configuration, mono-directional blocking circuit 204 may include two asymmetrically conductive components 208, 210. Filter circuit 206 may include capacitor 212 coupled to ground 214 that is sized to remove any undesirable AC signal components. An example of capacitor 212 may include a 470 microfarad capacitor available from Mouser Electronics.

[0041] One implementation of driver signal 104 generated by signal generation system 102 may be a driver signal that has a duty cycle of less than 25%. Specifically and in a preferred embodiment, driver signal 104 may have a duty cycle between 6.5% and 13%, wherein during 6.5%-13% of the waveform of driver signal 104, driver signal 104 has an amplitude of 3.3 to 60 VDC and during 87%-93.5% of the waveform of driver signal 104, driver signal 104 has an amplitude of 0 VDC. The above-described implementations of driver signal 104 are intended to be illustrative and not all inclusive. Accordingly, these are intended to be merely examples of the various driver signals that be utilized by signal generation system 102.

Operation of the Signal Generation System

[0042] Concerning driver signal 104 generated by signal generation system 102, the rise time of driver signal 104 may be critical to the overall function and performance of hydrogen generation chamber 110. Accordingly, a rise time as close to instantaneous as possible (e.g., as close to a truly vertical sweep) may result in the most efficient operation of hydrogen generation chamber 110. Further, the amplitude of driver signal 104 may be increased/decreased to vary the performance of hydrogen generation chamber 110 and the quantity of hydrogen 112 produced.

[0043] Signal generation system 102 may be configured to provide for adjustments in the pulse width and/or duty cycle of driver signal 104. Any pulse width and/or duty cycle adjustments may be based on the desired chamber performance. The timing of the duty cycle of driver signal 104 may establish a base frequency for driver signal 104. In a preferred embodiment, the pulse base frequency of driver signal 104 may range from 100 hertz to 10 kilohertz (however, frequencies outside of this range may also be utilized).

[0044] The diodes (e.g., asymmetrically conductive components 208, 210) utilized in mono-directional blocking circuit 204 may perform several functions. Typically, Schottky diodes have forward biases of approximately 1 mA in the range 0.15 to 0.46 volts. This lower forward voltage may provide for higher switching speeds and better system

efficiency, wherein Schottky diodes are considered to have essentially instant reverse recovery time.

[0045] The two diodes (e.g., asymmetrically conductive components 208, 210) may provide a first stage voltage clamp that may enhance rise time and forward current build up, which may be important during each startup of the OCP. The blocking diodes (e.g., asymmetrically conductive components 208, 210) may provide transient voltage suppression during initial charging of hydrogen generation chamber 110. This may allow hydrogen generation chamber 110 to reach full voltage amplitude in the least amount time.

[0046] The two diodes (e.g., asymmetrically conductive components 208, 210) may also prevent voltage returned from hydrogen generation chamber 110 from interfering with pulsed DC source signal 202, thus isolating the downstream circuit (e.g., signal processing system 106) during the off cycle while the reactive part of this circuit is in the recovery phase and exposed to a return voltage in the range of 0.90 VDC to 4.5 VDC.

[0047] Referring to FIG. 7, there is shown a portion of one implementation of signal generation system 102. Signal generation system 102 may include pulsed DC source 200 configured to generate pulsed DC signal 202. Signal generation system 102 may include a switching system 230 configured to receive pulsed DC signal 202 and generate pulse DC signal 236. Signal generation system 102 may include may include mono-directional blocking circuit 204 (as shown in FIG. 2) configured to receive pulsed DC source signal 236 and generate driver signal 104. Signal generation system 102 may also include filter circuit 206 (as shown in FIG. 2) configured to filter driver signal 104 and remove AC components.

[0048] Switching system 230 may include at least one power generation system 232, an example of which is a separate power bus connected to a power supply such as a battery, solar panel, or similar power generator. In a typical configuration, power generation system 232 may be configured to supply voltage from 0 to 60 volts. Switching system 230 may include at least one switch 234, an examples of which is a transistor, such as 2N2222 available from Newark Element 14, 2N7000 MOSFET available from Newark Element 14, or 55Y5202 DC to DC switch available from Newark Element 14.

[0049] One implementation of pulsed DC source 202 may be a driver signal that has a duty cycle of less than 25%. Specifically, and in a preferred embodiment, pulsed DC source 202 may have a duty cycle between 1% and 13%, wherein during the 1%-13% of the waveform of pulse DC signal 202, pulse DC signal 202 has an amplitude of 3.3 to 60 VDC and during 87%-99% of the waveform, pulse DC signal 202 has an amplitude of 0 VDC. The above-described implementations of pulse DC signal 202 are intended to be illustrative and not all inclusive.

[0050] One implementation of pulsed DC signal 236 may be a driver signal that has a duty cycle identical to that of pulsed DC signal 202. In particular, pulsed DC source 236 may be a driver signal that has a duty cycle of less than 25%. Specifically, and in a preferred embodiment, pulsed DC signal 236 may have a duty cycle between 1% and 13%, wherein during the 1%-13% of the waveform of pulsed DC signal 202, pulse DC signal 202 has an amplitude of 3.3 to 60 VDC and during 87%-99% of the waveform, pulse DC signal 202 has an amplitude of 0 VDC. The above-described

implementations of pulse DC signal 202 are intended to be illustrative and not all inclusive.

[0051] One implementation of signal generation system 102 includes pulsed DC signal 202 configured as a timer signal to turn switch 234 on and off at a given frequency and with a given duty cycle. Switch 234 is configured to receive pulsed DC signal 202 and conduct power from power generation system 232 by means of pulsed DC signal 236 to monodirectional blocking circuit 204 (shown in FIG. 2) during the on time of pulsed DC signal 202. Switch 234 is thus configured to generate pulsed DC signal 236 which has the same frequency and duty cycle as pulsed DC signal 202 and which may have a voltage that differs from pulsed DC signal 202. In a preferred embodiment, pulsed DC signal 236 may have a voltage that ranges from 0 to 60 VDC.

[0052] Referring to FIG. 8, there is shown a portion of one implementation of signal generation system 102. Signal generation system 102 may include pulsed DC source 200 configured to generate pulsed DC signal 202. Signal generation system 102 may include a selection system 250 configured to receive pulsed DC signal 202 and generate a plurality of one or more pulsed DC signals 258. Signal generation system 102 may include may include one or more mono-directional blocking circuit 204 (shown in FIG. 2) configured to receive a plurality of one or more pulsed DC signal 258 and generate driver signal 104 (shown in FIG. 2). Signal generation system 102 may also include one or more filter circuit 206 (shown in FIG. 2) configured to filter driver signal 104 and remove AC components.

[0053] Selection system 250 may include at least one power generation system 252, an example of which is a separate power bus connected to a power supply such as a battery, solar panel, or similar power generator. In a typical configuration, power generation system 252 may be configured to supply voltage from 0 to 60 volts. Selection system 250 may include at least one counter system 254 configured to receive pulsed DC signal 202 and generate a counter signal 255. An example of counter system 254 may include an integrated circuit counter such as Texas Instruments CD4026BE available from Newark Element 14. Counter system 254 may be selected based on the number of pulsed DC signals 258 desired. Selection system 250 may include at least one demultiplexer 256 configured to receive counter signal 255 and generate a plurality of one of more pulsed DC signals 258 over one or more output channels 257. An example of demultiplexer 256 includes Texas Instruments SN74LS139AN available from Newark Element 14.

[0054] In a preferred embodiment, pulsed DC signal 202 may be a driver signal that has a frequency from 100 Hz to 100 kHz and a duty cycle of 1% to 13%. Counter 254 is configured to received pulsed DC signal 202 and generate counter signal 255 which acts as an addressing signal that may control demultiplexer 256. Demultiplexer 256 receives counter signal 255 which enables one or more output channels 257, and passes power from power generation system 252 to one or more mono-direction blocking circuits 204 (shown in FIG. 2). As a result, the one or more pulsed DC signals 258 may have the same frequency and duty cycle as pulsed DC signal 202, and the same voltage as power generation system 252. The mono-directional blocking circuit 204 (shown in FIG. 2) may be configured to receive the the one or more pulsed DC signals 258 and generate one or more pulsed DC signals 104 (shown in FIG. 2). As a result, the one or more pulsed DC signals 104 may have the same

frequency and duty cycle as pulsed DC signal **202**, and the same voltage as pulsed DC signal **258**.

Positive Reactive Circuit Configuration

[0055] Referring to FIG. 3, there is shown one implementation of signal processing system **106**, wherein signal processing system **106** is shown to include positive reactive circuit **300**. Positive reactive circuit **300** may be coupled to anode **302** of hydrogen generation chamber **110**.

[0056] In one implementation, positive reactive circuit **300** may include inductive component **304** and capacitive component **306**. One example of inductive component **304** may include a 10 microhenry inductor available from Mouser Electronics. Inductive component **304** may be in parallel with capacitive component **306**. Capacitive component **306** may be sized based, at least in part, upon one or more physical characteristics of hydrogen generation chamber **110** (e.g., size, shape, electrode type, configuration and dimensions) and/or one or more physical characteristics of feedstock **114** (e.g., feedstock type and contents included therein) contained within hydrogen generation chamber **110**.

[0057] Inductive component **304** may be constructed of (or formed from) several individual inductors that may be arranged (in a parallel and/or series configuration) to achieve the desired inductance value. Additionally (and as will be discussed below), capacitive component **306** may be constructed of/formed from several individual capacitors that are arranged (in a parallel and/or series configuration) to achieve the desired capacitive value.

[0058] In one implementation, capacitive component **306** may include a plurality of discrete capacitors. For example, capacitive component **306** may include three discrete capacitors (e.g., capacitors **308**, **310**, **312**) arranged in parallel to form a parallel capacitor circuit. In one particular implementation, capacitor **308** may be a 45 microfarad capacitor available from Mouser Electronics, capacitor **310** may be a 1 picofarad capacitor available from Mouser Electronics, and capacitor **312** may be a 5 nanofarads capacitor available from Mouser Electronics. This parallel capacitor circuit (e.g., the parallel combination of capacitors **308**, **310**, **312**) may be coupled in parallel with inductive component **304**, wherein the output of the parallel capacitor circuit (e.g., the parallel combination of capacitors **308**, **310**, **312**) and inductive component **304** may be provided to anode **302** of hydrogen generation chamber **110**.

[0059] In this particular implementation, positive reactive circuit **300** may be configured as a band-stop filter. As is known in the art and in signal processing, a band-stop filter (or band-rejection filter) is a filter that passes most frequencies unaltered (i.e., unattenuated), while attenuating those frequencies that are within a defined range. As with any other LC filter, the particular range of frequencies that are attenuated may be defined based upon the value of the capacitors (e.g., capacitors **308**, **310**, **312**) and inductors (e.g., inductive component **304**) included within positive reactive circuit **300**.

Negative Reactive Circuit Configuration

[0060] Referring to FIG. 4, there is shown one implementation of signal processing system **106**, wherein signal processing system **106** is shown to include negative reactive circuit **400**. Negative reactive circuit **400** may be coupled to cathode **402** of hydrogen generation chamber **110**.

[0061] In one implementation, negative reactive circuit **400** may include inductive component **404** and capacitive component **406**. One example of inductive component **404** may include a 100 microhenry inductor available from Mouser Electronics. Inductive component **404** may be in parallel with capacitive component **406**. Capacitive component **406** may be sized based, at least in part, upon one or more physical characteristics of hydrogen generation chamber **110** (e.g., size, shape, electrode type, configuration and dimensions) and/or one or more physical characteristics of feedstock **114** (e.g., feedstock type and contents included therein) contained within hydrogen generation chamber **110**.

[0062] Inductive component **404** may be constructed of/formed from several individual inductors that may be arranged (in a parallel and/or series configuration) to achieve the desired inductance value. Additionally (and as will be discussed below), capacitive component **406** may be constructed of/formed from several individual capacitors that are arranged (in a parallel and/or series configuration) to achieve the desired capacitive value.

[0063] In one implementation, capacitive component **406** may include a plurality of discrete capacitors. For example, capacitive component **406** may include three discrete capacitors (e.g., capacitors **408**, **410**, **412**) arranged in parallel to form a parallel capacitor circuit. In one particular implementation, capacitor **408** may be a 1 microfarad capacitor available from Mouser Electronics, capacitor **410** may be a 1 picofarad capacitor available from Mouser Electronics, and capacitor **412** may be a 5 nanofarads capacitor available from Mouser Electronics. This parallel capacitor circuit (e.g., the parallel combination of capacitors **408**, **410**, **412**) may be coupled in parallel with inductive component **404**, wherein the output of the parallel capacitor circuit (e.g., the parallel combination of capacitors **408**, **410**, **412**) and inductive component **304** may be provided to cathode **402** of hydrogen generation chamber **110**.

[0064] In this particular implementation, negative reactive circuit **400** may be configured as a band-stop filter. As is known in the art and in signal processing, a band-stop filter (or band-rejection filter) is a filter that passes most frequencies unaltered (i.e., unattenuated), while attenuating those frequencies that are within a defined range. As with any other LC filter, the particular range of frequencies that are attenuated may be defined based upon the value of the capacitors (e.g., capacitors **408**, **410**, **412**) and inductors (e.g., inductive component **404**) included within negative reactive circuit **400**.

Feedback Circuit Configuration

[0065] Referring to FIG. 5, there is shown one implementation of signal processing system **106**, wherein signal processing system **106** is shown to include feedback circuit **500**. Feedback circuit **500** may be configured to couple anode **302** of hydrogen generation chamber **110** to cathode **402** of hydrogen generation chamber **110**.

[0066] In one implementation, feedback circuit **500** may include capacitive component **502**. Capacitive component **502** may be sized based, at least in part, upon one or more physical characteristics of hydrogen generation chamber **110** (e.g., size, shape, electrode type, configuration and dimensions) and/or one or more physical characteristics of feedstock **114** (e.g., feedstock type and contents included therein) contained within hydrogen generation chamber **110**.

[0067] Capacitive component **502** may include two discrete capacitors (e.g., capacitors **504**, **506**). In one particular implementation, capacitor **504** may be a 1 microfarad capacitor available from Mouser Electronics and capacitor **506** may be a 1 microfarad capacitor available from Mouser Electronics. A first of the discrete capacitors (e.g., capacitor **504**) may be coupled to anode **302** of hydrogen generation chamber **110**. A second of the discrete capacitors (e.g., discrete capacitor **506**) may be coupled to cathode **402** of hydrogen generation chamber **110**.

[0068] Feedback circuit **500** may include asymmetrically conductive component **508**, wherein asymmetrically conductive component **508** may be positioned between the two discrete capacitors (e.g., capacitors **504**, **506**). One example of asymmetrically conductive component **508** may include but is not limited to a diode (e.g., a light emitting diode), such as a RED/diffused T-1 (3 mm) 696-SSL-LX3044ID available from Mouser Electronics.

Operation of the Signal Processing System

[0069] Concerning the reactive circuits (e.g., positive reactive circuit **300** and negative reactive circuit **400**), these circuits may incorporate an inductor in parallel with plurality of capacitors (as discussed above). Upon the initiation of the OCP, these inductors may oppose any rise in current. This opposition may be part of the electronic clamp during the rise time of the OCP. The capacitors in parallel with the inductor may start to charge during the rise time of the OCP and provide a path for electron flow in the direction of hydrogen generation chamber **110**.

[0070] These capacitors may not be able to overcome the voltage amplitude of hydrogen generation chamber **110** and, therefore, may not be able to discharge during the OCP time. As these capacitors may be relatively small and may reach full charge status during the rise time of OCP and may remain charged during the duration of the OCP.

[0071] The slight opposition to current change (by the inductor) during the OCP rise time may quickly dissipate, wherein the inductor opposes current change based upon magnetically induced resistance to the current flow.

[0072] Hydrogen generation chamber **110** may function as a load for signal processing system **106**, wherein hydrogen generation chamber **110** may have a varying internal resistance and a varying voltage amplitude. Hydrogen generation chamber **110** may behave similarly to an inductive/capacitive electronic component, wherein variations may occur based upon varying electrolytic conditions that can vary dramatically during the rise time of the OCP. These varying conditions may continue during the length of the duty cycle and may be in the form of a charge ion state triggering charging of hydrogen generation chamber **110**. The electron density within hydrogen generation chamber **110** may increase dramatically within hydrogen generation chamber **110**. This electron density may be at its greatest at a circumference slightly larger than the outer diameter of cathode **402**.

[0073] The ON cycle rise time and duration of the duty cycle may cause a molecular polarity shift within the electrolytic fluid (e.g., feedstock **114**). This molecular polarity shift may have a corresponding electromagnetic/electrostatic component. Due to the shape and geometry of hydrogen generation chamber **110** and without a defined electron flow pathway, the electromagnetic component will have a chaotic characteristic, wherein this chaotic characteristic

may assist in the molecular splitting of gas atoms from the water molecules within the electrolytic fluid (e.g., feedstock **114**) due to a constant molecular charge imbalance.

[0074] The OFF cycle of signal processing system **106** may start at the beginning of the OFCP. The blocking diodes (e.g., asymmetrically conductive components **208**, **210**) are in the cutoff state which may isolate signal generation system **102** from signal processing system **106**. A pulsed DC input base signal set to one kilohertz may reach the cutoff state one-thousand times per second. During the OFF cycle, the electrolytic fluid (e.g., feedstock **114**) in hydrogen generation chamber **110** may change from a charge state to a reset discharge cycle. During this OFF cycle, all electronic interactions may be energized from energy recovered (or harvested) from hydrogen generation chamber **110**.

[0075] The charge amplitude of hydrogen generation chamber **110** may have a characteristic fast decline from greater than 3.5 VDC to less than 1.4 VDC. The decline curve sweep angle may be dependent on the pulsed DC input frequency and the configuration of the reaction circuits (e.g., positive reaction circuit **300** and negative reaction circuit **400**).

[0076] During the cutoff initiation, the first decline sequence to occur is the collapse of the electron density column surrounding cathode **402**. This high density electron column may be held in place by the induced magnetic field that is a result of the OCP. This collapse may cause an electronic flashback (or rapid energy release) from hydrogen generation chamber **110** to the reactive circuit (e.g., positive reaction circuit **300** and/or negative reaction circuit **400**), which is similar to an electrostatic discharge and may provide the electrolytic fluid (e.g., feedstock **114**) with a pathway to start a change in state of polarity releasing additional stored energy.

[0077] Once the electron column proximate cathode **402** starts to collapse, there is a fast rise in potential on negative reactive circuit **402**. At this point, there may be an imbalance with positive reactive circuit **302**. The inductor within negative reactive circuit **402** may have a rise in potential imposing an impedance value that may allow the parallel capacitors to discharge in the opposite direction to the charge state during the OCP. This situation may create a latching circuit potential through hydrogen generation chamber **110** as the pathway for electron flow.

[0078] The return energy from hydrogen generation chamber **110** may be a DC signal with embedded AC components, wherein these AC components may be relatively small in amplitude. The AC components may be driven by the molecular polarity shift after the cutoff sequence is initiated and the imbalance of the charge state of hydrogen generation chamber **110**. The DC component produced by hydrogen generation chamber **110** may be clamped to swing the AC wave into the positive range.

[0079] The capacitors in the reactive circuits (e.g., positive reaction circuit **300** and/or negative reaction circuit **400**) may charge stabilize after the electrostatic release from the DC component. The inductors may provide timing sequences and preload for capacitor charge/discharge sequence while minimizing circuit resistance at peak input values. The capacitors may subsequently discharge under the influence of the AC components. The result may be an amplification of the embedded frequency waves providing a charge/discharge cycle at these given frequencies. This sequence may continue until the molecular polarity rotation

of hydrogen generation chamber **110** is stabilized or the charge imbalance of the reactive circuit (e.g., positive reaction circuit **300** and/or negative reaction circuit **400**) is diminished.

[0080] Feedback circuit **500** may be configured in reverse polarity to signal generation system **102** and signal processing system **106**. Feedback circuit **500** may function as a secondary load to the reset reaction of hydrogen generation chamber **110**. The capacitors (e.g., capacitors **504**, **506**) of feedback circuit **500** may collect electrons during the electrostatic discharge cycle, which may then be discharged through the light emitting diode (i.e., asymmetrically conductive component **508**).

[0081] Feedback circuit **500** may assist in minimizing the electrostatic discharge impact on other portions of the reactive circuit (e.g., positive reaction circuit **300** and/or negative reaction circuit **400**), which may result in the regulation of the timing of ON, OFF and Cutoff sequences. The light emitting diode (i.e., asymmetrically conductive component **508**) may minimize electrostatic interference, thus assisting in maintaining peak charge amplitudes during the reset sequence of hydrogen generation chamber **110**.

[0082] Specifically, the electrostatic charge may find a secondary pathway through the light emitting diode (i.e., asymmetrically conductive component **508**). The light emitting diode (e.g., asymmetrically conductive component **508**) may have a characteristic that allows static electricity to pass through while minimizing resistive load characteristics. This pathway may help regulate the discharge timing sequence while dissipating the accumulated charge on the capacitors (e.g., capacitors **504**, **506**). The switching or blocking characteristics of the light emitting diode (i.e., asymmetrically conductive component **508**) may also minimize current loss during the OCP.

[0083] Due to the reverse polarity of feedback circuit **500**, a portion of the recovered energy may be applied to the riding frequency during the cut off discharge sequence to assist in increasing the frequency amplitude. Further, the secondary electrostatic charge release may assist in the percentage of the desired gas output of hydrogen **112**. The electrostatic charge energy may only be recoverable during a given time interval, wherein if the time interval is too long, the electrostatic charge may interfere with the proper sequencing of the OCP and OFCP. Accordingly, the values of capacitors **504**, **506** may be adjusted to optimize the timing sequence.

Hydrogen Generation Chamber Configuration

[0084] Referring to FIG. 6, there is shown one implementation of hydrogen generation chamber **110**. Hydrogen generation chamber **110** may include at least one hollow cylindrical anode **302** configured to contain feedstock **114**. At least one cathode **402** may be positioned within hollow cylindrical anode **302**. Cathode **402** may be positioned along a longitudinal centerline (i.e., longitudinal centerline **600**) of hollow cylindrical anode **302**. Accordingly, hydrogen generation chamber **110** may be configured as a coaxial hydrogen generation chamber, as cathode **402** and hollow cylindrical anode **302** share a common centerline (namely longitudinal centerline **600**).

[0085] Cathode **402** may be constructed, at least in part, of tungsten. For example, cathode **402** may be a tungsten rod. Hollow cylindrical anode **302** may be constructed, at least in

part, of graphite. For example, hollow cylindrical anode **302** may be machined from a block of graphite.

[0086] Hollow cylindrical anode **302** may have an outer surface **602** and an inner surface **604**, wherein the inside diameter (e.g., inside diameter **606**) of hollow cylindrical anode **302** is 2,400% to 2,600% of (i.e., 24-26 times larger than) an outside diameter (e.g., outside diameter **608**) of cathode **402** positioned within hollow cylindrical anode **302**. For example and in a preferred embodiment, hollow cylindrical anode **302** may have an inside diameter (i.e., inside diameter **606**) of 25.0 millimeters and cathode **402** positioned within hollow cylindrical anode **302** may have an outside diameter (e.g., outside diameter **608**) of 1.0 millimeter.

[0087] Cathode **402** positioned within hollow cylindrical anode **302** may have a longitudinal length (i.e., longitudinal length **610**) that is 190% to 210% of (i.e., 1.9-2.1 times longer than) inside diameter **606** of hollow cylindrical anode **302**. For example and in a preferred embodiment, cathode **402** positioned within hollow cylindrical anode **302** may have a longitudinal length of 50.0 millimeters (when hollow cylindrical anode **302** has an inside diameter (i.e., inside diameter **606**) of 25.0 millimeters).

[0088] Hydrogen generation chamber **110** may include feedstock recirculation system **612**. For example and in this particular illustrative embodiment, feedstock **114** may be drawn through first conduit **614** and gas contractor **616** and into fuel reservoir **618**. Fuel reservoir **618** may serve as a preconditioning zone to maintain feedstock and catalyst concentrations at desired levels. Feedstock **114** may be pulled through circulation pump **620** and then through heat exchanger **622** (to e.g., maintain a desired temperature for feedstock **114**) and returned to hydrogen generation chamber **110** via conduit **624**.

[0089] Gas collection system **626** may be coupled to hydrogen generation chamber **110** and may be configured to collect hydrogen **112** generated by hydrogen generation chamber **110** from feedstock **114**. In this particular illustrative example, hydrogen **112** may be drawn through conduit **628** by vacuum pump **630**, which then may pass through cold trap **632** and flow meter **634** and into e.g., storage container **636**.

[0090] In certain implementations, as illustrated in FIG. 9 for example, hydrogen generation chamber **110** may include a plurality of discrete chambers. Accordingly, hollow cylindrical anode **302** may include a plurality of hollow cylindrical anodes **302** configured to contain feedstock **114** and cathode **402** may include plurality of cathodes **402** each of which may be positioned within a corresponding or associated one of the plurality of hollow cylindrical anodes **302**. Specifically, hydrogen generation chamber **110** may be configured so as to include multiple anode/cathode pair, thus increasing the production of hydrogen **112**. The plurality of generation chambers may be arranged in varying shapes. The generation chamber of FIG. 9 is cylindrical while that illustrated in FIG. 10 is rectangular for example. The chambers may also be arranged in a plurality of layers with each layer having a plurality of chambers.

General

[0091] A method or process in accordance with certain implementations may be described with reference to FIG. 11. Process **1100** may include the generation of a driver signal at step **1110**. The driver signal may be a pulsed DC

signal. The driver signal may be processed to generate a chamber excitation signal at step 1120. The chamber excitation signal may be applied to a hydrogen generation chamber to generate hydrogen from a feedstock contained within the chamber at 1130. The hydrogen generation chamber includes at least one hollow cylindrical anode configured to contain the feedstock and at least one cathode positioned within the chamber at least one hollow cylindrical anode.

[0092] The terminology used herein is for the purpose of describing particular embodiments only and is not intended to be limiting of the disclosure. As used herein, the singular forms “a”, “an” and “the” are intended to include the plural forms as well, unless the context clearly indicates otherwise. It will be further understood that the terms “comprises” and/or “comprising,” when used in this specification, specify the presence of stated features, integers, steps, operations, elements, and/or components, but do not preclude the presence or addition of one or more other features, integers, steps, operations, elements, components, and/or groups thereof.

[0093] The corresponding structures, materials, acts, and equivalents of all means or step plus function elements in the claims below are intended to include any structure, material, or act for performing the function in combination with other claimed elements as specifically claimed. The description of the present disclosure has been presented for purposes of illustration and description, but is not intended to be exhaustive or limited to the disclosure in the form disclosed. Many modifications and variations will be apparent to those of ordinary skill in the art without departing from the scope and spirit of the disclosure. The embodiments chosen and described in order to best explain the principles of the

disclosure and the practical application, and to enable others of ordinary skill in the art to understand the disclosure for various embodiments with various modifications as are suited to the particular use contemplated. For example, while hydrogen generation was described, other gases can also be generated including, but not limited to oxygen, carbon, nitrogen, etc. The signal can be applied selectively to the chamber to adjust, increase or decrease the generation of one or more of these gases based on a particular application.

[0094] A number of implementations have been described. Having thus described the disclosure of the present application in detail and by reference to embodiments thereof, it will be apparent that modifications and variations are possible without departing from the scope of the disclosure defined in the appended claims.

What is claimed is:

1. A method for generating hydrogen, the method comprising:
 - generating a driver signal, wherein the driver signal is a pulsed DC signal;
 - processing the driver signal to generate a chamber excitation signal; and
 - applying the chamber excitation signal to a hydrogen generation chamber to generate hydrogen from a feedstock contained within the chamber wherein the hydrogen generation chamber includes:
 - at least one hollow cylindrical anode configured to contain the feedstock, and
 - at least one cathode positioned within the at least one hollow cylindrical anode.

* * * * *