

Aug. 22, 1933.

L. C. KARRICK

1,923,213

PROCESS AND APPARATUS FOR CARBONIZING COAL

Filed May 23, 1928

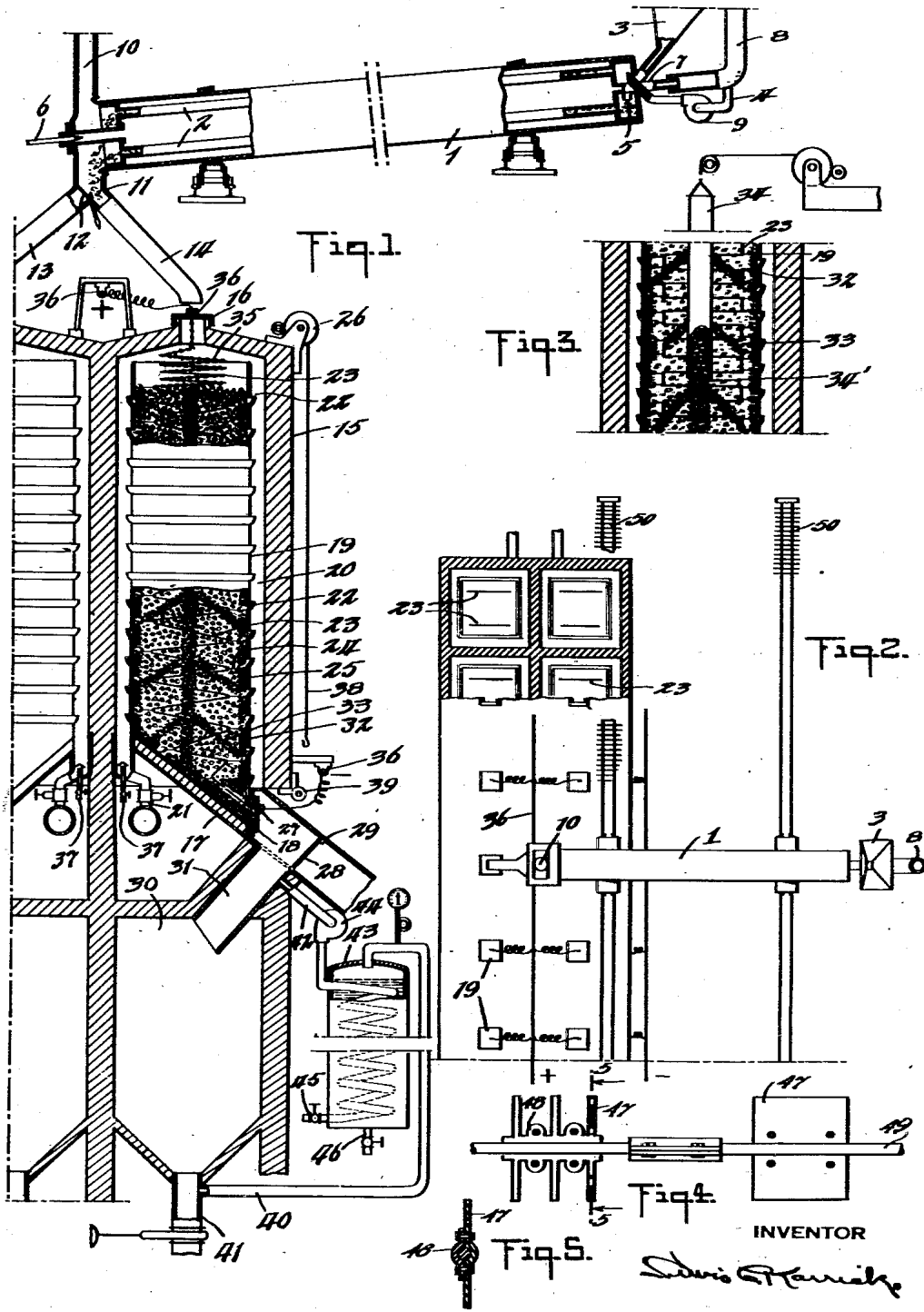

UNITED STATES PATENT OFFICE

1,923,213

PROCESS AND APPARATUS FOR CARBONIZING COAL

Lewis C. Karrick, New York, N. Y.

Application May 23, 1928. Serial No. 280,026

12 Claims. (Cl. 202—13)

This invention relates to process and apparatus for carbonizing coal and other carbonaceous materials in very large masses.

5 An object of the invention is to treat such materials under controlled conditions to produce coke of great density and compactness, resembling anthracite, with simultaneous production of valuable by-products.

10 Other objects of the invention are to utilize electricity, particularly available off-peak power, as an economical source of heat for treating carbonaceous materials; to provide improved means for carbonizing various grades of coals, including low rank as well as highly fusible coals; and to provide improved means for breaking the solidified coke into lumps of any desired dimensions.

20 A feature of the invention resides in heating the interior of a heavy confined mass of material, such as bituminous coal, at relatively low temperatures over comparatively long periods of time, thus simulating to an unusual degree nature's process of producing anthracite.

25 Another feature of the invention resides in heating the material by means of electrical resistors disposed in the interior of the mass, preferably in the form of heavy metallic cables or chains which are strung in a spiral or zigzag path to effect substantially even heating while using minimum heat gradients within the mass. At the conclusion of the heat treatment the electrical conductors are forcibly withdrawn to break the solidified coke apart and aid its withdrawal from the chamber. The construction and arrangement of the electrical conductors may be varied to control the rate of distillation as well as the size and shape of the lumps into which the coke is broken.

40 From an economic standpoint the invention may best be employed at a central station, preferably hydro-electric, or other source of cheap power. By heating the material slowly, over a few days or up to two weeks, depending upon the coal, the spacing of the elements and the temperatures applied, I not only obtain products of better quality than can be obtained by rapid heating, but am also able to utilize available off-peak power at irregular intervals and in varying quantities as available from the power source. This will balance the load on power generating stations and result in material savings in the cost of the kilowatt.

55 Although the material treated may be run-of-mine bituminous coal, it will be more profitable to treat slack coal since an equally high yield

and character of gas, tar-oils and coke may be obtained therefrom. I produce an extremely dense coke in very large angular blocks from low grade or cheap classes of coal which were formerly of relatively little value in the domestic market, thus greatly enhancing the value of such coals particularly in markets where large lump coal sells at a premium. The coke which I produce may be kindled as easily as raw coal, will burn freely in open fireplaces, and is smokeless in combustion. It is superior to raw coal in every type of household or industrial appliance in which raw coal is used, and has none of the objections frequently met, especially by inexperienced persons, in burning high-temperature cokes. I have produced gases varying from 1500 cubic feet of 1,000 B. t. u., to 6,000 cubic feet of 600 B. t. u. per ton of Utah coal and 35 gallons of tar-oils from which I derived motor fuel superior to the average gasoline, in addition to tar acids, lubricating oils, waxes and resins. A greater volume of gas was derived by carrying the devolatilization much further, but in no case was the temperature used high enough to cause a measurable degree of high-temperature dissociation as takes place in a by-product or gas oven.

In carrying out the invention, the material, such as bituminous coal, is preferably preheated in neutral or reducing gases so as to preserve the coking characteristics of the coal. The use of oxidizing gases such as stack gases is undesirable since it is found to oxidize the coking or agglutinating ingredients and may largely destroy the coking properties of some coals. I prefer to pre-heat the coal to about 350° C. in any suitable pre-heater, using a cheap fuel as a source of heat, to remove all moisture from the coal and to bring the coal substance to a state of incipient fusion or distillation. At this temperature the coal begins to give off exo-thermic heat with gradually increases the rate of distillation and efficiency of the process.

The preheated coal is charged directly into large heat insulated chambers in which the low temperature carbonization is carried out by applying heat to the interior of the coal mass. The chambers may be square, round or of any other suitable construction, but should be very high so that the weight of the superimposed coal charge aids in compressing the coke as it forms, thereby producing a very dense product. Heat is supplied evenly to all parts of the charge by means of one or more flexible electric resistors of heavy wire rope, chain, etc., mounted in series,

60
65
70
75
80
85
90
95
100
105
110

parallel, or any combination within the chambers. The resistors are rigidly supported in a definite position in the chambers during charging so that the various strands or portions of the resistor will maintain their original positions in the mass of coal during the distilling operation. I prefer to arrange the resistors in spiral or zig-zag form within the charge so that there will not be more than about two feet of coal between adjacent portions of the resistor, or more than about one foot from the nearest section of the resistor to the margin of the coal mass through which the heat and the volatile products must flow.

The power supplied to the carbonizers will usually be irregular and for short or long duration in accordance with the power plant load requirements. I prefer that the capacity of the heating elements will not permit rapid heating. I have found that when heating is very slow so that from one to two days is required to complete the distillation, much lower temperatures are required than when the distillation is completed in a few hours. I have also found that slower heating produces tar-oils of very high quality closely resembling some types of petroleum. Furthermore, such slow distillation results in producing coke which is very dense, being more like anthracite than that obtained with rapid heating as applied in coke ovens or gas retorts. To obtain the best results I prefer to prolong the distillation to about one week and with some coals I prefer two weeks to finish the heating. It is evident that rapid heating may be applied simply by placing the heating elements closer together and using more power, but since the quality of the products is of greater importance than capacity, I prefer to use heating capacity and arrangement of the heating elements which will apply conditions of rate and temperature of heating which will produce the best character and yield of products. I have found that coals may be completely distilled of their condensable volatiles in one hour if heated to 525° C., but that if twenty-four hours are allowed the temperature used may be as low as 450° C. If seven to fourteen days are allowed to complete the distillation of the condensibles, the temperature required is in the neighborhood of 400° C. These latter temperatures are well within the range to which steel and cast iron may be subjected over long periods of time without substantial deterioration. At these temperatures flexible electric resistors of steel or wrought iron will give good service even though subjected to reducing atmospheres. A flexible heating element of chrome-iron alloy will give even better service.

In the preferred construction of the apparatus, herein described, I provide double walls around the charge of distilling coal, and the volatiles as formed pass through openings in the inner wall into the space between the walls whence they pass to condensers, separators and scrubbers of any suitable type. The openings in the inner wall preferably consist of channels extending about the walls and so formed that the vapors pass upwardly in elongated streams as they leave the carbonizing chamber.

When the charge has ceased giving off condensible volatiles, the electric circuit may be disconnected and the charge removed from the carbonizing chambers. To aid in dislodging the solidified coke, I provide means for forcibly withdrawing the flexible heating element in either direction to tear the coke apart. The flexible heating element may be so formed that it will

break the coke into blocks of any desired dimensions. In the preferred construction I provide doors at the bottom of the carbonizing chambers through which the flexible heating element is forcibly drawn by means of a winch. The blocks of coke pass through the door into a cooling pit and are there subjected to dry quenching, preferably with steam, which serves to produce superior kindling properties. After the coke is cooled to about 200° C. it has reached a safe storage temperature and may be screened and shipped.

In treating coals of the type which fuse and swell excessively in carbonizing, I mix the coal with one of the non-fusing type and thereby obtain a very dense coke. A fine coke may be used for blending to accomplish the same result. When the carbonizing chamber is of very large diameter and of great height, I prefer to provide a column of coarse coke in the center of the coal mass and also layers of coke at intervals of about three to six feet throughout the height of the charge in order to provide channels through which the volatiles may escape during distillation. Without such provision explosions might sometimes occur in distilling extremely fusible types of coals. I sometimes provide a coarse coke layer in between the coal charge and the walls of the carbonizing chamber, although this is not necessary with some coals because by charging at the center of the chamber the coal, in falling, forms a pyramid and the coarse lumps roll to the edges of the chamber and form a permeable layer in contact with the walls. This automatically provides for free movement of gases and vapors along the inner wall surface leading to the vapor outlets. However, if trial proves that the lumps of coal do not insure free exit for the vapors along the walls, I charge lump coke with the coal in sufficient quantity to provide a suitable layer against the walls; and in such case the coke lumps on dropping into the chamber roll to the margin of the mass and thereby form an open layer against the walls.

I sometimes provide a column of coke in the center of the coal mass by placing in the chamber a sheet metal pipe of suitable dimensions and shape, fill the pipe with coke, admit coal to the area in the chamber surrounding the pipe, and then hoist the pipe through the top of the chamber, leaving the column of coke intact. Such columns of coke may be placed at intervals throughout the charge. If the coal does not contain enough of the plastic or fusing ingredients to form a solid dense coke aggregate, I provide additional weight at the top of the charge which may be in the form of a layer or more of heavy chain, and may be a continuous portion of the electrical heating element. A very dense coke is thereby caused to form.

In the drawing:

Fig. 1 is a diagrammatic illustration of apparatus embodying the invention;

Fig. 2 is a plan view, partly in section, showing a battery of carbonizers adapted to be charged from a common preheater movable back and forth to serve the various units;

Fig. 3 is a view through a section of a carbonizing chamber illustrating the method of forming a column of coke in the mass of coal and a heating unit disposed within the mass;

Fig. 4 is a detail view showing one form of flexible electric heating element which may be employed; and

Fig. 5 is a section taken on the line 5—5 of Fig. 4. In the drawing, Fig. 1 shows a rotary preheater

1 heated internally with hot gas and containing a multiplicity of externally heated tubes 2 through which the coal passes in parallel flow with combustion gas; a coal charging spout 3; a hot gas connection 4 entering the coal feed compartment 5; a source of hot gas supply 6 for the preheater; and a waste gas outlet 7 to the stack 8. The preheater heats the coal to any desired temperature such as about 250° C. to 350° C., and in the case of young coals, may expel some of the initial volatiles consisting of oxides of carbon and hydrogen sulphide. Some of the hot gas passing to the stack 8 may be returned to contact with the coal so as to partially oxidize the coal and prevent it from fusing excessively in the carbonizer. To accomplish this, a blower 9 circulates part of the hot stack gas back into the feed end of the rotary preheater, whereupon they pass through the tubes with the coal and are discharged into the stack 10. The preheated coal falls into a charging device 11 where it is directed by diverting valve 12 and chutes 13 and 14 into the various carbonizing chambers.

The carbonizers 15 consist, for example, of tall square chambers of brick or of reinforced concrete and steel provided with a top gastight closure 16, a sloping floor 17, and discharge gate 18. The chamber has an inner or false wall 19 of perforated steel which is set a few inches from the reinforced concrete wall. The space 20 between the walls forms a vapor collecting space from which the vapors and gases pass out by connections 21 at the bottom to any suitable condensing and scrubbing system, not shown. The perforations 22 in the steel wall 19 consist of elongated channels which permit volatiles to escape upwardly but obstruct passage of any solid particles and obviate clogging owing to the type of perforation shown.

A resistor or electric heating element 23, which may be of wire rope but is preferably a link chain as shown in Fig. 1 is distributed evenly across the carbonizer pit throughout its height by suspending the element by short loops of light rope 24 which engage with hooks 25 fastened to the steel walls. The chain may be put in place easily by hand labor as follows: With the proper length of chain lowered into the carbonizing chamber by unwinding it from a winch 26, an attendant on a ladder will swing the chain to one side while he hooks the ends of the short piece of rope under the chain and around the first hook at the top. He then proceeds to the next lower hook on the opposite side and similarly fastens the resistor. By moving downwardly the task is quickly accomplished. At the bottom, the resistor is connected securely to the electrical terminal 27. Other similar strands of the resistor are installed likewise until the carbonizing elements are all in place, then the lower door 18 is closed.

A small quantity of coke is first charged into the carbonizer in sufficient depth to cover the discharging door. This material may become impregnated with tar oils during progress of distillation and will therefore be kept separate from the bulk of the coke product when the carbonizer is discharged at the end of the distillation. The diverting valve 28 in discharging chute 29 will be used to separate the material from the main body of coke which is discharged into the dry quenching pit 30 through chute 31.

Preheated coal is charged into the carbonizer directly from the preheater and on dropping to the bottom a cone-shaped pile forms and much

of the coarse material rolls to the bottom of the growing pile and builds up against the steel walls, thus depositing a permeable layer of lump coal at the sides through which the volatiles can find their way to the gas-perforations 22 leading to the vapor space 20. If the coal has been proved by test to be excessively fusible so that there is danger of the gas outlets 22 being sealed so that explosions may result, it will be desirable to resort to using a mixture of coals which will insure the desired degree of permeability of the mass. It may be preferable to charge simultaneously with the coal some lump coke 32 which will provide a layer against the perforated steel wall, or to charge intermittently a quantity of coke which will form strata 33 at suitable distances apart from the bottom to the top of the charge as shown in the drawing.

If the coal is excessively fusible it may be desirable to provide a column 34' of lump coke down through the center of the charge which intersects the coke layers, thus providing avenues of escape for the volatiles at suitable distances apart. This is preferably accomplished by lowering one or more elongated tubes 34 into the chamber and filling it with coke, as shown in Fig. 3. As the charging progresses the coal fills in around the electric heating elements 23 and the tube 34. The charge should preferably extend within a foot or so of the top of the carbonizer, leaving room for expansion of the charge. When the charging is completed the tubes 34 are withdrawn, for example by means of a winch, leaving columns of coke as shown in Fig. 3. If it is desired to produce a very dense coke, I provide for weighting the top of the charge. This may be accomplished with heavy link chain which may be a continuous portion 35 of the heating element. A pressure of a few ounces per square inch is usually sufficient to produce a dense coke when the coal is distilled very slowly so that the entire mass carbonizes evenly throughout. The most advantageous pressure for each coal must be determined by experiment.

The upper ends of the heating elements are fastened to the electrical connector 36 in the top of the carbonizer, the charging door 16 closed, and the distillation started.

The power supplied should never be so great as to cause the resistor to reach a destructive temperature of the metal by fusion or by excessive carburizing. The coal mass permits very slow conduction of heat so that a supply of power that would heat the element to a dull red heat in air would be damaging to the metal when buried in the insulating coal mass. A maximum temperature of 600° C. to complete the distillation of the condensable volatiles (the smoke-producing volatiles) should not be exceeded unless an element of chrome-iron or other suitable alloy is provided. The latter would be highly desirable to use made up in cast links. By using temperatures of the element below 600° C. the distillation will progress slowly and may extend over a period of one or possibly two weeks before the charge is finished. As the coal substance in contact with the element becomes converted to coke some current will be conducted through it so that the resistance may fall off and the flow of current become excessive. Suitable transformers, circuit breakers, meters, pyrometers, etc. should be provided to observe constantly and control the conditions existing in the distilling mass. The power is delivered to suitable terminals shown at 36.

Completion of the distillation of the conden-

sibles may be determined by noting when tar-oils cease to be produced from the coal as indicated by drawing out occasional samples of the volatiles from vapor space 20 through a cooled glass tube attached at sample pipes 37; the presence of any condensibles will be immediately observed from the discoloration caused by oils condensing on the glass tube. Also a gas meter may be inserted in the line coming from the condensers which will indicate when the desired amount of gas has formed from a predetermined size charge. From the gas volume produced, it can be determined when the condensibles are removed and also the amount of residual volatiles remaining in the coke, if the proximate analysis of the coal is known.

When the distillation is completed discharging door 18 is opened and the contaminated coke next to the door is drawn out separately. The resistor 23 is then disconnected from the terminal 27 and hooked onto the cable 38 leading around sheave 39 and on to winch 26. The cable passes through a hole in the top of chute 29. As the winch is operated the resistor is drawn out of the chamber while tearing loose the coke mass into large blocks. The ropes used to hold the resistor in place while charging are easily broken as they will have become carbonized during the heating. The blocks of coke are diverted by gate 28 through chute 31 into the dry-quenching pit 30 which holds the entire charge of coke from the carbonizer. The door 18 is then closed, the resistor again placed in position, and a fresh charge of coal is introduced and carbonized as above described. The resistor will have been wound up on winch 26 so that it can be lowered again into the chamber 19.

The valve door 28 on the chute 31 is closed tightly and the coke is ready for dry-quenching. Steam or gas is introduced by pipe 40 into pit 30 through the connection on the side of the unloading spout 41. The steam or gas rises through the coke mass and abstracts its sensible heat and passes out of the pit by insulated pipe 42 and thence to a heat exchanger 43 illustrated as an evaporator. If desired, air may be introduced at 40 and recycled through the coke mass and through the heat exchanger. The oxygen is quickly consumed so that the gas becomes a mixture of nitrogen and oxides of carbon. I prefer, however, to use steam which is generated by utilizing the greater total heat of the steam coming from the hot coke to supply the required heat. I also prefer to operate the heat exchanger 43 under pressure so that much of the latent heat of the superheated steam from the pit may be recovered in the production of fresh steam at lower pressure in the heat exchanger. The blower 44 will produce the necessary pressure inside the condensing tubes to effect a transfer of heat from the condensing steam (containing some gases) to the surrounding water from which the steam is produced. The heat exchanger in this case becomes an evaporator. However, if the fresh steam is generated from the sensible or superheat of the dry-quenching steam there will be no need for using high pressures entering heat exchanger 43 any more than to overcome the friction head in the pit and in the heat exchanger. The condensed steam, some tar-oils, and fixed gases are continuously removed from the exchanger by pressure-regulating valve 45. Fresh water enters the evaporator at valve 46.

I prefer with some coals to use flexible heating elements with projecting points or fins so as to

assist the propagation of conducted heat into the coal mass and in order that the projecting members will cause the coke to break along certain planes of fracture defined by the fins or projecting points. Fig. 4 shows such members, 47 being cast or forged plates having projecting fins as shown. The fins do not materially increase the cross-section of the plates nor affect its current-carrying capacity, but function principally as means of conducting heat more rapidly into the coal mass. I also provide clamping portions 48 for clamping the plates 47 to a wire rope conductor 49. This form of resistor has the further advantage of great weight so that it aids in compressing the coke as formed. Fig. 5 is a sectional view showing the manner of clamping the plates 47 upon the wire rope conductor 49 by means of the clamping plates 48.

In Fig. 2 a battery of carbonizers 15 are adapted to be charged successively, as required, by a common preheater 1 which is movable back and forth above the carbonizing chambers on tracks 50. The common preheater is moved along the tracks 50 until the chutes 13 and 14 register with the openings 16 at the top of the carbonizing chambers, whereupon the charge is admitted in the manner described above. In Fig. 3 the flexible electric conductor 23 is shown strung substantially horizontally between the walls of the inner chamber 19, instead of being tapered, thus heating all parts of the coal mass evenly.

I claim:

1. A process for heating a thick mass of solid carbonizable material to produce massive blocks of coke and other substances, which comprises effecting a heating of the material at a carbonizing temperature without access to the air from a heat source positioned in recurring convolutions throughout the mass of said material to produce substantially even distillation, said heat source simultaneously serving to compress the coke and forcibly rupturing the residue by the application of force at points along the recurring convolutions of the heat source, whereby the residue may be broken into desired pieces.

2. A process for heating solid carbonizable material to produce coke and other substances, by positioning within the material an elongated substance effective strength of which is not destroyed by heating at the carbonizing temperature of the material, which comprises effecting a heating of the material without access to the air at a carbonizing temperature from the heat source adjacent the said substance by causing the passage of electric current along the line of the heat source to thereby heat and distil said material, and effecting a reduction of the residue into pieces by forcefully rupturing the material along the line of the substance.

3. The combination with a reaction chamber comprising walls adapted to retain solid carbonizable material when delivered thereinto, of a flexible heating element arranged within said chamber for contacting with material in the chamber, and a plurality of fragile members supporting the heating element within said chamber which are adapted to be ruptured by the forcible removal of said heating element.

4. The combination with a reaction chamber comprising walls adapted to retain a solid carbonizable material, of a flexible heating element extending in a tortuous path within the chamber, means for admitting solid carbonizable material to said chamber for contacting with the flexible heating element, and a plurality of members sup-

- porting the heating element in the chamber formed at least partly of carbonizable material so that they may be broken upon the application of force tending to withdraw the heating element from the chamber.
5. The combination with a reaction chamber having substantially vertical walls, of a plurality of fasteners mounted on said walls, a flexible metallic member in said chamber supported by and strung back and forth between and in close proximity to said fasteners, supporting means for connecting said flexible metallic member to the fasteners, said supporting means comprising non-conducting carbonizable strands, means for admitting carbonizable material to said chamber to substantially envelope said flexible member, and means for heating said flexible member to distil said carbonizable material.
6. The combination with a reaction chamber comprising walls adapted to retain solid carbonizable material, of a flexible resistance heating member for conducting on electric current extending in a tortuous path within said chamber, means for admitting solid carbonizable material to the chamber, means for supplying electric current to the flexible heating member to effect a heating of the same and a resultant heating of the material at a carbonizable temperature to produce coke, and means for withdrawing said flexible member and effecting a rupturing of the coke into pieces as determined by the spacing and arrangement of said heating member within the mass of coke.
7. The combination with a reaction chamber comprising walls adapted to retain a solid carbonizable material, of a flexible heating element extending in a tortuous path within the chamber, means for admitting solid carbonizable material to said chamber for contacting with the flexible heating element, and means for forcibly withdrawing said element to dislodge the residue after the reaction.
8. The combination with a reaction chamber comprising walls adapted to retain solid carbonizable material of a flexible heating element extending in a zig-zag path with the flights thereof arranged substantially horizontally across the chamber, means for admitting carbonizable material to said chamber for contacting with the flexible heating element, and means for withdrawing of the heating element from the chamber to cause the rupturing of the residue into pieces as determined by the spacing and arrangement of said heating element within the mass of coke.
9. The combination with a reaction chamber adapted to contain solid carbonizable material, of a flexible electric conductor extending in a zig-zag path substantially from one wall portion of the chamber to the other, strips supporting the conductor within said chamber formed of a carbonizable but electrical non-conducting material, means for causing the passage of an electrical heating current through said conductor to distil the carbonizable material and to cause carbonization of said strips of material so that they may be readily broken, and means for forcibly withdrawing said conductor from said chamber to tear the mass of carbonizable material apart.
10. The combination with a reaction chamber comprising substantially vertical walls, of a flexible member strung back and forth in the space between said walls, supporting means for the member adapted to be rendered ineffective to retain the same when force tending to withdraw the member is applied therethrough, supporting means for the member adapted to be rendered ineffective to retain the same when force tending to withdraw it is applied thereto, means for admitting carbonizable material to said chamber to substantially envelope said flexible member, and means for effecting a heating of said flexible member to distil said carbonizable material.
11. The combination with a reaction chamber, of a flexible metallic resistance member adapted to conduct an electric current, said flexible member being arranged in a tortuous path through the major part of said chamber, the member being so spaced as to be out of electrical contact with the walls of the reaction chamber, means for admitting solid carbonizable material to said chamber to substantially surround said member, means for supplying electric current to said member to effect heating of the same and the resultant distillation of the carbonizable material, and means for forcibly withdrawing the member from the bottom of the chamber for rupturing the surrounding material.
12. The combination with a vertical retort adapted to receive a mass of carbonizable material, of a heavy flexible electric conductor disposed in said chamber of a length sufficient to extend throughout the entire length of the vertical retort and with a portion thereof collected into a mass in the upper part of the retort so that the mass will provide a weight to effect a yielding pressure on material which may be placed in the retort, means for passing an electric current through said conductor to effect the heating thereof whereby when carbonizable material is placed in the retort a portion of the conductor is adapted to be collected into a mass and placed loosely on top of the material so as to exert a downward yielding pressure on all positions of the material while the conductor is heated to act as a heating source.

LEWIS C. KARRICK.

80
85
90
95
100
105
110
115
120
125
130
135
140
145
150