

## Chemistry 111 Laboratory

### Experiment 6: Synthesis of a Coordination Compound

#### Introduction

This experiment serves as an introduction to the area of synthetic chemistry – and more specifically, to inorganic synthesis. You are going to make some new chemical bonds as you synthesize a large molecule from smaller ones! You will be synthesizing a *coordination compound*. The bonds in coordination compounds are two-electron bonds (like covalent bonds), but both electrons come from the ligand (a Lewis base with an unpaired electron pair). The metal ion serves as a Lewis acid (an electron-deficient species which can use its empty orbitals for the bond). The pictures below show the ligands we will be using and a representation of the bonding in a coordination complex.

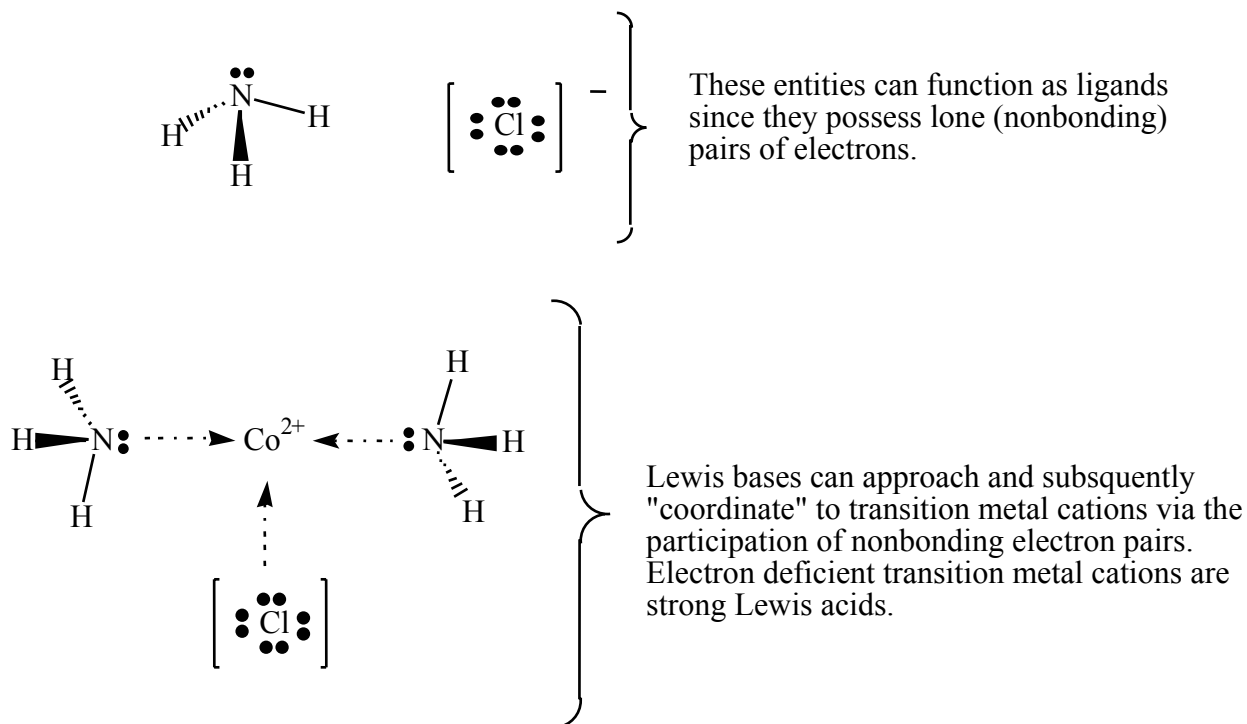

You will have the opportunity to synthesize one of two possible coordination complexes in this experiment. One molecule is named hexaamminecobalt(III) chloride. Its formula is written [Co(NH<sub>3</sub>)<sub>6</sub>]Cl<sub>3</sub>. The other molecule is named pentaamminechlorocobalt(III) chloride. Its formula is written [Co(NH<sub>3</sub>)<sub>5</sub>Cl]Cl<sub>2</sub>.

The ammonia and chloride ligands of these complexes use lone pairs of electrons to form bonds with the cobalt cation. The coordination number for the cobalt in both products is six and these cations are octahedral, as predicted by VSEPR theory. The cobalt ion ends up having a charge

of 3+; each chloride ion is 1-, and the ammonia ligands are neutral, so  $[\text{Co}(\text{NH}_3)_6]$  has a net 3+ charge and  $[\text{Co}(\text{NH}_3)_5\text{Cl}]$  has a net 2+ charge. These complex cations crystallize from solution as chloride salts. The overall reactions for the syntheses of these salts are very similar:

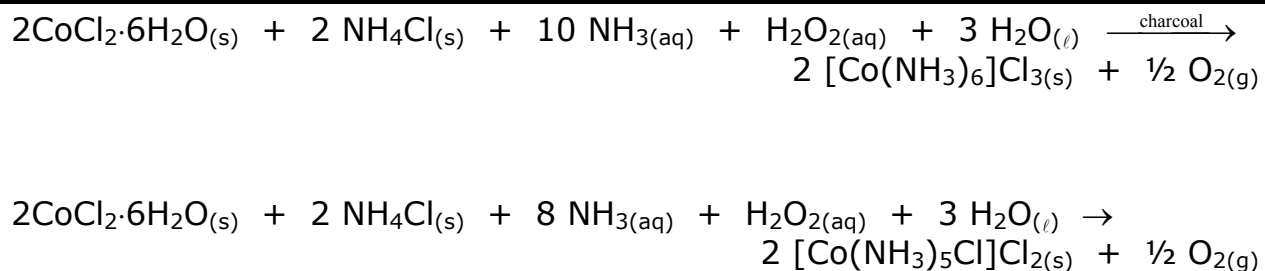

Notice that cobalt(II) chloride is hygroscopic and is available as the hydrate:  $\text{CoCl}_2 \cdot 6\text{H}_2\text{O}$ . The dot in this formula implies a strong association between the cobalt(II) chloride and the water molecules. This is **not** a chemical bond, but a result of water being incorporated into the crystal structure of  $\text{CoCl}_2$  (in a very specific way!) as the solid forms. The 6 does indicate the stoichiometric relationship between the components of this material: there are 6 water molecules in the crystal for every Co atom and every two Cl atoms.

As you follow the procedure, keep complete records of your observations in your laboratory notebook. Record what your eyes, ears, and nose detect! (But don't inhale the fumes above or stick your ear into the reaction vessel – that's dangerous!) Often in syntheses small things can go slightly wrong which alter the reaction in some way. Accurate notes that describe each step of a protocol as it was actually implemented, and the observed result each step along the way, help document where a procedure has gone awry. **Your laboratory score for this experiment will be primarily based on the quality of your "running account:" your summary of what you did and what you observed throughout the synthesis. Be sure to write down what you did, after you do it, rather than writing down what you will do in your lab book.**

**Procedures – ONLY DO ONE!**

Note: Your instructor will direct you to synthesize *either*  $[\text{Co}(\text{NH}_3)_6]\text{Cl}_3$  or  $[\text{Co}(\text{NH}_3)_5\text{Cl}]\text{Cl}_2$ .

### Synthesis A: Preparation of $[\text{Co}(\text{NH}_3)_6]\text{Cl}_3$

1. Set up a hot water bath on your hotplate, using a 1000 mL beaker containing 200 mL of deionized water. Turn the hotplate on at its minimum setting. Turn on your VWR digital thermometer, and place the probe in the water. Set the body of the thermometer up on the center console of the lab bench, so that the cord does not get scorched.
2. Select a clean 250 mL beaker with *gradations (volume marks)* from your lab drawer. This will be your “reaction beaker”. **Inspect it carefully** for cracks or other signs of damage. It will be heated, so we want to make sure it is sound. If none of the beakers available to you are both clean and marked with approximate volumes, please ask for one.
3. Weigh  $10.0 \pm 0.2$  g of ammonium chloride ( $\text{NH}_4\text{Cl}$ ) directly into your 250 mL reaction beaker, using a top-loading balance. Record the exact amount used (to the precision limit of the top-loading balance).
4. Add 40. mL of deionized water to your reaction beaker and stir until most of the solid ammonium chloride dissolves.
5. Weigh  $8.0 \pm 0.2$  g of cobalt (II) chloride hexahydrate directly into your reaction flask. Record the exact amount added (to the precision limit of the top-loading balance).
6. Stir the reaction mixture until most of the solids dissolve.
7. **IN THE HOOD**, add 40. mL of 15 M ammonia, pumping slowly and smoothly so that none spatters. **CAUTION: This is a concentrated basic reagent with a strong odor.** Stir your reaction mixture with your stirring rod for about thirty seconds.
8. Add approximately 0.8 g of activated charcoal. Transfer this directly from the reagent bottle into your reaction beaker. **Try to avoid spilling, as this stuff makes a mess. If you spill any, clean it up immediately with a wet paper towel, before it stains someone's clothes, lab book, etc.** The activated charcoal serves as a *catalyst* for the reaction that forms the bonds between  $\text{NH}_3$  and Co. Conveniently, it also catalyzes the transformation of  $\text{Co}^{2+}$  into  $\text{Co}^{3+}$  by the  $\text{H}_2\text{O}_2$ !
9. **IN THE HOOD**, add 50. mL of 10%<sub>mass</sub>  $\text{H}_2\text{O}_2$  **one pump at a time**, stirring between *each* pump. **CAUTION: Be careful to not spill or spatter this reagent on your skin: use gloves.** There will be some effervescence as oxygen gas is evolved. Remain in the hood and keep stirring until all the bubbling stops. The purpose of the hydrogen peroxide ( $\text{H}_2\text{O}_2$ ) is to convert the cobalt from  $\text{Co}^{2+}$  to  $\text{Co}^{3+}$ .

10. Once all bubbling has stopped, place your 250 mL reaction beaker in your 1000mL hot water bath, which should be at roughly 60°C. If all is going well, your reaction mixture volume should be  $135 \pm 5$  mL, and your solution should be almost deep maroon in color.
11. Leave the reaction beaker in the water bath for 30-40 minutes, while maintaining the temperature of the water bath between 50°C and 70°C. Stir periodically, avoiding the fumes above the reaction beaker when you do.
13. After at least 30. minutes, remove your 250 mL reaction beaker from the water bath. It is safest to do this with your hand, rather than to attempt to use the beaker tongs.
14. Set up a cold water bath, using a 400 ml beaker containing 150 ml of cool tap water. Cool the reaction beaker in the cold water bath for 2 minutes. Then transfer it to one of the ice baths in the sinks, stirring occasionally as it cools. This helps promote crystallization. (Use a CheckTemp 1 digital thermometer probe placed directly in the reaction mixture to monitor the temperature. Keep your reaction beaker in the ice bath until the temperature reads less than 10°C when the reaction mixture is stirred.)
15. Set up a Büchner funnel apparatus. Filter the mixture using #1 filter paper moistened with deionized water. You don't have to get all the solid out of your reaction beaker, or clean the reaction beaker, as you'll be pouring the precipitate (solid) right back into the reaction beaker. Pull air through the solid in the funnel for at least a minute, to dry it out.
16. Turn off the vacuum. Release the vacuum on the sidearm flask by twisting off the vacuum hose as you pull gently. Rotate the filter cup of the Büchner funnel to free it from the rest of the apparatus.
17. Knock or scrape the contents of the filter cup, including the filter paper, back into your 250 mL reaction beaker. You do not need to clean or rinse your reaction beaker.
18. Rinse the filter cup with deionized water from your squirt bottle, into the reaction beaker.
19. Pick up the filter paper with the plastic tweezers provided. Use your squirt bottle, filled with deionized water, to rinse all the colored cobalt compound off of the filter paper. (It's Ok if some black material remains on the filter.)
20. Discard the used filter paper in the trash, unless it is still colored.
21. **Discard the filtrate (liquid) into the aqueous cobalt waste container.**
22. Using your squirt bottle, rinse down the sides of the reaction beaker and your stirring rod into the reaction beaker. Add deionized water to your reaction beaker until the total solution volume is approximately 100 mL, as indicated by the gradations on the beaker.

23. IN THE HOOD, add 5 mL of 12 M HCl, and stir.  
**CAUTION: 12 M HCl a concentrated acidic reagent with a choking odor.**
24. Heat the mixture to boiling directly on your hot plate while stirring to dissolve the crystals. **DO NOT ATTEMPT TO MEASURE THE TEMPERATURE.** You may set the hotplate to 10, provided you stir frequently. (Otherwise, don't exceed 6.)
25. Rinse the suction flask with deionized water and reassemble your Büchner funnel. (You can do this while waiting for the previous step). You don't need to clean the filter cup.
26. Turn off the hotplate. Holding the reaction beaker securely with a pair of beaker tongs, pour the hot reaction mixture, a little at a time, onto the moistened filter paper in the Buchner funnel apparatus, under suction. This removes the charcoal. If the filtration stops, ask for help, and **do not add more liquid!** Squirt deionized water at any colored material remaining in the reaction flask, and pour the resulting colored water out into the funnel. Stop rinsing when no color remains, even if some black material is left behind.
27. The filtrate should be orange, and it **contains the dissolved product.** Do not discard it!
28. Wipe any residual carbon out of the reaction beaker with a paper towel. Wipe any residual carbon off of your stirring rod as well. Rinse the reaction beaker with hot tap water and then with de-ionized water. You don't need to dry it completely.
29. Transfer your filtrate to the cleaned out 250-mL reaction beaker. Swirl the sidearm flask just before transferring portions of the liquid: try to transfer any solid present in the flask into the reaction beaker. However, do not add any water to the system: don't rinse!
30. IN A HOOD, add 15 mL 12 M HCl to your reaction beaker, and stir.  
**CAUTION: This is a concentrated acidic reagent with a choking odor.**
31. Place your reaction beaker in the ice bath in the sink. Stir the reaction mixture as it cools. Continue to stir and cool the mixture until its temperature has been below 10° C for at least 5 minutes. You can carry out the next step while you wait.
32. Clean the filter cup of your filtering apparatus. Unless the used filter paper in your funnel has a color (other than black), throw the used filter paper (with the carbon black on it) into the trash, using your scoopula to scrape it out. Wipe out any remaining carbon with a moist paper towel. Do this over another paper towel, because the bottom of the filter cup may have a yellow Co compound on it. Reassemble the filtering apparatus. Before you put it in and wet it, determine the mass of the filter paper you will use in the next step. Use a top-loading balance, making the determination to  $\pm 0.01$  g.

33. Filter the cold precipitated product suspension by pouring it onto the moistened filter paper while the suction is on. To transfer as much of your product as possible, stir the reaction mixture with your stirring rod just before you pour out the portions, and pour pretty quickly, a little at a time. Some product will remain in the reaction beaker – don't attempt to rinse it out, or you will dissolve away some of your product!
34. Draw air through the crystals for five minutes.
35. Weigh a clean, dry watchglass to  $\pm 0.01$  g on a top-loading balance.
36. Transfer the crystals *and* your filter paper to the watchglass by “burping” the vacuum hose, removing the filter cup, and inverting the filter cup onto the watchglass. You may have to tap or thump the filter cup a few times to get the product to fall out.
37. Place your emptied filter cup into the solids collection bin in the hood. Please do not attempt to clean it.
38. Rinse your reaction beaker with the minimum amount of water from your squirt bottle needed to dissolve all remaining yellow product. Pour the cobalt-contaminated (colored) water into the filter flask.
39. With it still in the filter flask, rinse down the white, funnel-shaped portion of your Büchner funnel into the sidearm flask, using your squirt bottle and stir bar to scrape and wash off any solid material. Get all the color off both the funnel and your stirring rod.
40. If your filtrate is only faintly colored, pour it down the sink. If it does have a distinct color (and it may), pour it into the aqueous cobalt waste jug.
41. Put the watchglass in your drawer to dry.
42. Clean up, following your instructor's directions.
43. Next laboratory period, you'll weigh your product to determine your synthetic yield.

## Synthesis B: Preparation of $[\text{Co}(\text{NH}_3)_5\text{Cl}]\text{Cl}_2$

1. Set up a hot water bath on your hotplate, using a 1000 mL beaker containing 200 mL of deionized water. Turn the hotplate on and set it to power level 2. Turn on your VWR digital thermometer, and place the probe in the water. Set the body of the thermometer up on the center console of the lab bench, so that the cord does not get scorched.
2. Select a clean 250 mL beaker with *gradations (volume marks)* from your lab drawer. This will be your “reaction beaker”. **Inspect it carefully** for cracks or other signs of damage. It will be heated, so we want to make sure it is sound. If none of the beakers available to you are both clean and marked with approximate volumes, please ask for one.
3. Weigh  $4.0 \pm 0.1$  g of ammonium chloride ( $\text{NH}_4\text{Cl}$ ) directly into your 250 mL reaction beaker, using a top-loading balance. Record the exact amount used (to the precision limit of the top-loading balance).
4. **IN THE HOOD**, slowly add 25 mL of 15 M ammonia. Stir to dissolve the  $\text{NH}_4\text{Cl}$ .  
**CAUTION: This is a concentrated basic reagent with a strong odor.**
5. Weigh  $8.0 \pm 0.2$  g of cobalt (II) chloride hexahydrate directly into your reaction flask. Record the exact amount added (to the precision limit of the top-loading balance). **IN A HOOD**, stir the solution until the solid chunks of cobalt (II) chloride hexahydrate are dissolved and can no longer be seen from underneath. A tan slurry in a deep red to brown liquid should result.
6. **IN THE HOOD**, add 20 mL of 10%<sub>mass</sub>  $\text{H}_2\text{O}_2$  *one pump at a time*, stirring between *each* pump. **CAUTION: This reagent can cause severe skin burns. Be careful to not spill or spatter this reagent on your skin and use gloves when handling it.** There will be some effervescence as oxygen gas is evolved. The solution will get hot as the reaction proceeds. Remain in the hood and keep stirring until all the bubbling stops. Use your stirring rod to insure that any tan material on the walls of the beaker comes into contact with the hydrogen peroxide solution. The purpose of the hydrogen peroxide ( $\text{H}_2\text{O}_2$ ) is to convert the cobalt from  $\text{Co}^{2+}$  to  $\text{Co}^{3+}$ .
7. **IN THE HOOD**, stirring between each addition, add 25 mL of 12 M HCl, 5 mL at a time. White dust will form above your beaker, but don't freak. (Ammonium chloride dust is produced as HCl reacts with the ammonia escaping from your reaction mixture.)  
**CAUTION: Hydrochloric Acid is a concentrated acidic reagent with a choking odor.**
8. Heat the mixture in your hot water bath on the hotplate to  $75^\circ - 85^\circ\text{C}$  for 30 minutes. Stir periodically, avoiding the fumes above the reaction beaker when you do. Your reaction

beaker should contain a deep purple solid in a beautiful indigo solution, with both colors changing somewhat as you stir and heat.



9. Remove the beaker from the water bath after at least 30 minutes have passed. Keep the water bath on the hotplate: it will be needed again later.
10. Cool the beaker to room temperature in a cool water bath, consisting of a 400 ml beaker filled with approximately 150 ml of cool water. Once the beaker is no longer hot, transfer it to an ice bath. Keep it there until its temperature drops below 10°C, as measured with a Check Temp 1 digital thermometer placed in the reaction mixture.
11. Set up a Büchner funnel apparatus. Place a piece of #1 filter paper in the Büchner funnel. Moisten the filter paper with deionized water. Using suction, filter the mixture through the filter paper. You don't have to get all of the solid out of your reaction beaker, or clean the reaction beaker, as you'll be pouring the precipitate (solid) right back into the reaction beaker. Pull air through the solid in the funnel for at least a minute, to dry it out.
12. Turn off the vacuum. Release the vacuum on the sidearm flask by twisting off the vacuum hose as you pull gently. Rotate the filter cup of the Büchner funnel to free it from the rest of the apparatus.
13. Knock or scrape the contents of the filter cup, including the filter paper, back into your 250 mL reaction beaker. You do not need to clean or rinse your reaction beaker.
14. Rinse the filter cup with deionized water from your squirt bottle, into the reaction beaker.
15. Pick up the filter paper with the plastic tweezers provided. Use your squirt bottle, filled with deionized water, to rinse all the colored cobalt compound off of the filter paper.
16. Discard the used filter paper in the trash, unless it is still colored.
17. **Discard the filtrate (liquid) in the aqueous cobalt waste container.**
18. Using your squirt bottle, rinse down the sides of the reaction beaker and your stirring rod into the reaction beaker. Add deionized water to your reaction beaker until the total solution volume is approximately 35 mL, as indicated by the gradations on the beaker.
19. IN THE HOOD, add 25 mL of 15 M ammonia directly to the reaction flask, and stir.
20. IN THE HOOD add 60 mL of 12 M HCl directly to the reaction beaker.
21. Heat the solution to 80-85°C in your hot water bath for thirty minutes.
22. Cool your reaction beaker in the cool water bath (400 mL beaker) for 2 minutes. Then transfer it to one of the ice baths in the sinks, stirring occasionally as it cools. This helps

promote crystallization. (As before, use a CheckTemp 1 digital thermometer in the reaction mixture to monitor the temperature.)

23. Before you put it in and wet it, determine the mass of the filter paper you will use in the next step. Use a top-loading balance, making the determination to  $\pm 0.01$  g.
24. Reassemble your Büchner funnel apparatus. (You do not need to rinse out the sidearm flask.) Filter the cold precipitated product suspension by pouring it onto the moistened filter paper while the suction is on. To transfer as much of your product as possible, stir the reaction mixture with your stirring rod just before you pour out the portions, and pour pretty quickly, a little at a time. Some product will remain in the reaction beaker – don't attempt to rinse it out, or you will dissolve away some of your product!
25. Draw air through the crystals for five minutes.
26. Weigh a clean, dry watchglass to  $\pm 0.01$  g on a top loading balance.
27. Turn off the suction, and release the vacuum by “burping” the hose: while twisting, pull on the vacuum hose to remove it from the sidearm flask, then stick it back on.
28. Transfer the crystals *and* your filter paper to the watchglass by inverting the filter cup onto the watchglass. You may have to tap or thump the filter cup a few times to get the product to fall out.
29. Place your emptied filter cup into the solids collection bin in the hood. Please do not attempt to clean it.
30. Rinse your reaction beaker with the minimum amount of water from your squirt bottle needed to dissolve all remaining yellow product. Pour the cobalt-contaminated (colored) water into the filter flask.
31. With it still in the filter flask, rinse the white, funnel-shaped portion of your Büchner funnel into the sidearm flask, using your squirt bottle and stir bar to scrape and wash off any solid material. Get all the color off both the funnel and your stirring rod.
32. If your filtrate is only faintly colored, pour it down the sink. If it does have a distinct color (and it may), pour it into the aqueous cobalt waste jug.
33. Put the watchglass in your drawer to dry.
34. Clean up, following your instructor's directions.
35. Next laboratory period, you'll weigh your product to determine your synthetic yield.

## *Safety Considerations*

- **This lab involves several dangerous chemicals, each of whose hazards increase with temperature. Work carefully, thoughtfully, and slowly. Don't guess: ask!**
- If you mistakenly skip a synthetic step, consult with your instructor! Don't go back and do it out of sequence without asking for advice: dangerous reactions can occur!
- The hydrogen peroxide ( $\text{H}_2\text{O}_2$ ) used in this lab is a strong oxidizer. *Treat it with great respect.* **You must wear gloves when working with this reagent.** As long as you have them on, we recommend you keep them on for subsequent steps.
- 15M ammonia ( $\text{NH}_3$ ) is a concentrated base. If you get it on your skin (it will feel cold), rinse with copious amounts of hot water and soap. It constantly releases ammonia gas, which is very capable of paralyzing your diaphragm muscle and stopping your breathing. Avoid ammonia fumes!
- 12 M hydrochloric acid (HCl) is a concentrated, corrosive acid. Avoid eye contact with it at all costs. Avoid skin contact as well, as it can cause severe burns. If your skin is exposed (it will itch), wash thoroughly with cold water and soap. HCl gas is constantly released from this reagent, and it can burn your nasal passages. Avoid the fumes, and work in a hood when adding this reagent to your reaction mixture.
- Cobalt is not particularly hazardous, as transition metals go, but it is not good for you, either. It isn't really bad for the environment, but we would like to keep large quantities out of the water supply. Luckily, Co is strongly colored in almost all its aqueous manifestations, so it is easy to spot. Consequently:
  - Please dispose of any strongly colored solutions in the aqueous cobalt waste jugs. Dilute (pale-colored) solutions can be dumped down the drain.
  - Please place any solids contaminated with Co (colored liquids or solids) into the solids collection bin in the hood.
  - To reduce the volume of waste we generate, please do not add clean (nearly Co-free) water or solid materials to these waste containers.
- Even if you are super-buff, please do not attempt to take apart the Büchner funnels while they are under vacuum. Always release the vacuum by "burping" the vacuum hose first: **twist** and gently pull on the vacuum hose, with the vacuum line turned off, to remove the hose and release the vacuum. *Then* you can twist out the filter cup, pull out the funnel base and the rubber stopper, and do other fun stuff. Also, because the vacuum hoses are quite stiff and the sidearm flasks expensive, be sure to **clamp the sidearm flask firmly in place, touching the countertop [not held up above it], except when the flask is being emptied and/or cleaned.**

### ***Helpful Hints!***

- Your stirring rod is the reaction beaker's friend. They are old pals, went to school together. Keep them together. To avoid leaving Co compounds everywhere, introducing impurities into your product, or losing your stirring rod, keep it in your reaction beaker throughout your experiment.
- Label your various beakers with Sharpies, so you know what's in them!
- Do not clean Büchner apparatus except when and as indicated in the instructions
- Any strongly colored aqueous solutions should go in the aqueous cobalt waste jug
- Please be sure to work in the hoods when the lab tells you to do so – some reaction steps give off unpleasant gases that you don't want to snort up!
- Static electricity generated by the gloves makes the balances go crazy! Don't put them on until you are done weighing, and take them off before weighing your filter paper.
- Keep the VWR digital thermometer in your water bath – don't put it in your reaction mixture. Put the body of the thermometer up on the center console of the lab bench, so that the cord leading to the probe does not get scorched by the hotplate burner.
- It's OK to put the CheckTemp 1 digital thermometer probes directly into the reaction mixture. They can take it. Please don't do this with the uppity VWR thermometers.

### **Report**

Your report for this experiment will consist of your laboratory notebook pages. We will be looking for a description of what *you did*, what the *reaction mixture did*, and what *you thought* about it all. Make sure that all information is clearly displayed. Additionally, please answer the following two questions at the end of **NEXT WEEK'S LAB**. (You will not have the necessary information until next week!)

1. Calculate the yield for your synthesis. Provide all calculations associated with your percent yield determination in your lab notebook.
2. There are two common factors that contribute to yields of less than 100%. One is simply the employment of a synthetic reaction step whose kinetics or equilibrium prevent complete reaction, or encourage side reactions that lead to the generation of products other than the one desired. The other common factor is the physical loss of reaction materials during the synthesis. Which of these was most evident in your work? Where does it appear that major losses might have occurred?

**Chemistry 111 Laboratory**  
**Experiment 6: Synthesis of a Coordination Compound**  
**Advance Study Assignment**

I know those of you in the Thursday section won't have much time to do this, so we have decided to make this ASA due at the start of *next week's* lab, instead of this week. So you don't have to have this ASA ready to hand in before you do the lab described herein – relax.

Note: “Nominal” quantity means the amount the lab tells you to aim for, without worrying about uncertainty. For example, the nominal mass of  $\text{CoCl}_2 \cdot 6\text{H}_2\text{O}_{(s)}$  is 8 grams.

Please fill in the following table, based on the nominal quantities specified in each synthesis. Clearly show your calculations, on a separate sheet of paper.

(Note: For each reagent, you'll want to determine the total amount used throughout the given synthesis...not just the amount added the first time the reagent is mentioned in the lab.)

Quantity	Synthesis A	Synthesis B
Mass of $\text{CoCl}_2 \cdot 6\text{H}_2\text{O}_{(g)}$ used (g)		
Mass of $\text{NH}_4\text{Cl}_{(s)}$ used (g)		
Volume of 15 M $\text{NH}_3_{(aq)}$ used (mℓ)		
Volume of 12 M $\text{HCl}_{(aq)}$ used (mℓ)		
Volume of 10% <sub>mass</sub> $\text{H}_2\text{O}_2_{(aq)}$ used (mℓ)		
Mass of $\text{H}_2\text{O}_2$ used (g, approximate*)		
Moles of Co used (moles)		
Moles of $\text{NH}_4\text{Cl}$ used (moles)		
Moles of $\text{NH}_3$ used (moles)		
Moles of $\text{HCl}$ used (moles)		
Moles of $\text{H}_2\text{O}_2$ used (moles)		

\*Since the  $\text{H}_2\text{O}_2$  is mostly water, you may approximate its density to be that of water, 1.0 g/mℓ

With this table filled in, and consulting the over reactions given at the start of this lab, answer the following questions:

1. What is the theoretical yield (in grams) for Synthesis A based, on the nominal quantities indicated in the procedure? Explain your work, and clearly indicate which ingredient you conclude to be the limiting reagent.
2. What is the theoretical yield (in grams) for Synthesis A based, on the nominal quantities indicated in the procedure? Explain your work, and clearly indicate which ingredient you conclude to be the limiting reagent.